

M O D U L A R B O R I N G P R O G R A M

WWW.PINZBOHR.COM

WEB CATALOG

TABLE OF CONTENTS

PRODUCT OVERVIEW	2
STANDARD BORING HEADS	
ROUGH HEADS 75° APPROACH	4
ROUGH HEADS 90° APPROACH	7
FINISH HEADS 75° APPROACH	10
FINISH HEADS 90° APPROACH	13
MICRO BORING HEADS	16
ISO BORING BARS	17
INDEXABLE BORING BARS FOR A 42 016	18
INDEXABLE STANDARD CARTRIDGES	19
INDEXABLE SPECIAL CARTRIDGES	20
ARBORS FOR BORING HEADS	
MAS BT 403 - BT 30, 40, 45, 50	21
DIN 69871 - AS 30, 40, 45, 50	24
DIN 2080 - OTT 30, 40, 50	27
DIN 69893 - HSK 50, 63, 100	29
DIN 228 - MORSE 2, 3, 4	30
DIN 1806 - MORSE 5	31
DIN 1835 - WELDON 20, 25, 32, 40	32
R8 HOLDERS	33
ACCESSORIES	
EXTENSION PIECES	34
COOLANT-FEEDING EXTENSIONS	34
REDUCERS	35
45° CHAMFERING HEADS	35
ADAPTORS	36
SPARE PARTS	
FINISH BORING HEADS	38
ROUGH BORING HEADS	39
LARGE DIAMETER FINISH BORING HEADS	40
LARGE DIAMETER ROUGH BORING HEADS	41
ASSEMBLY SYSTEM FOR LARGE BORING HEADS	42
INSERTS	43

PRODUCT OVERVIEW

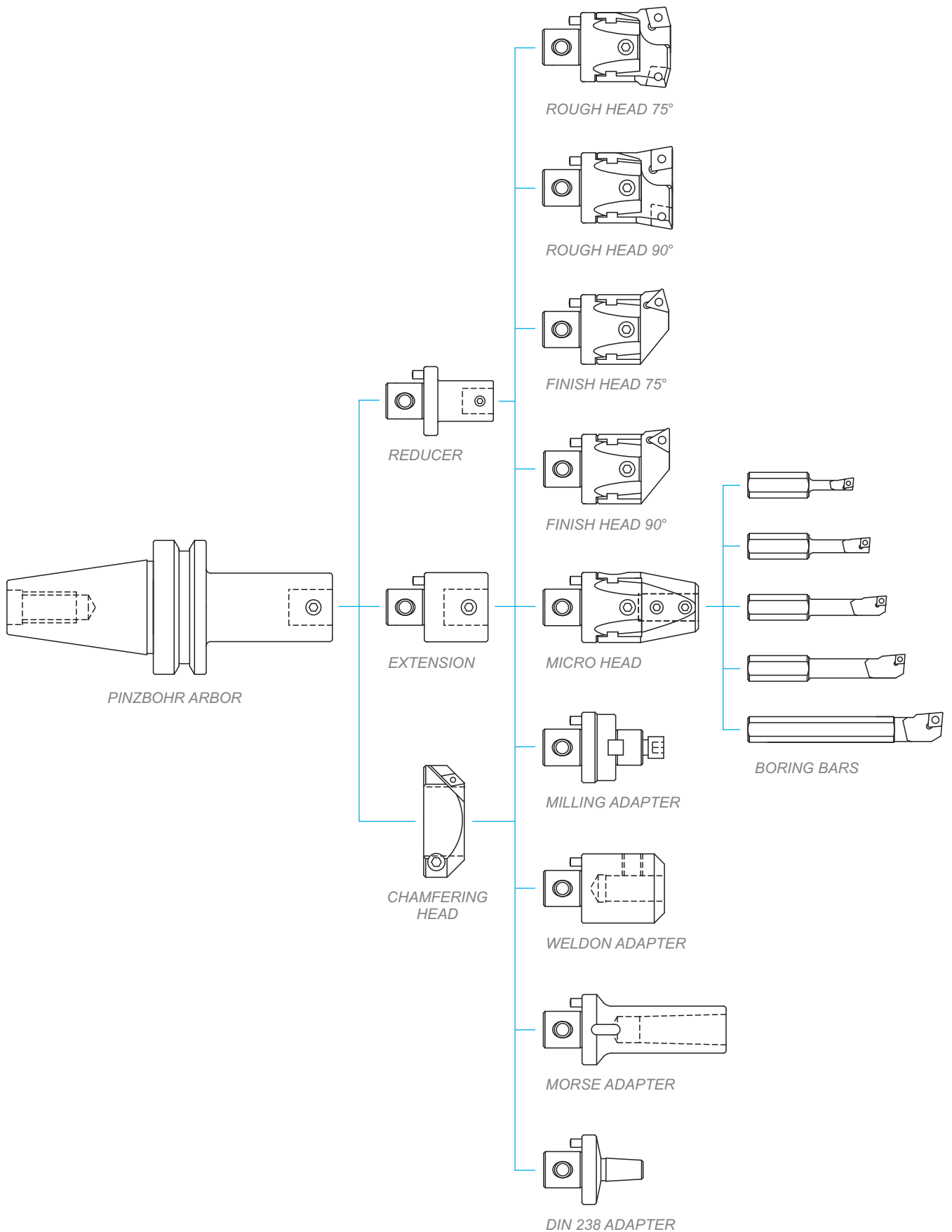

PRODUCT OVERVIEW

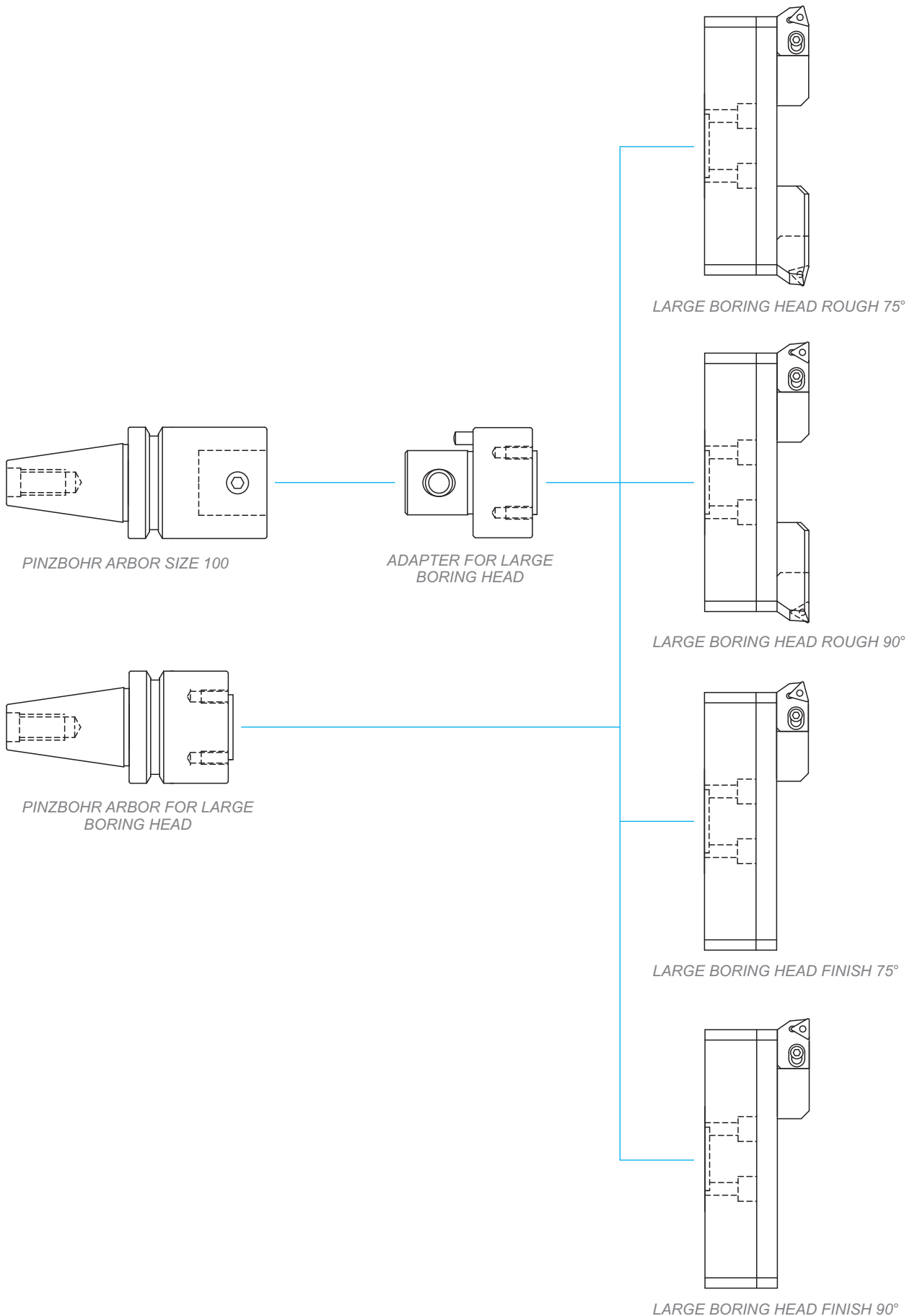

ROUGH HEADS 75° APPROACH

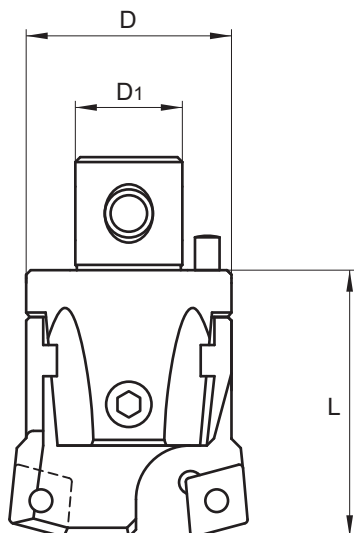

INTEGRAL POCKET TYPE HEADS SYNCHRONIZED ADJUSTMENT

Bore Range		Dimension			Product Number	Insert	Clamp Screw	Kg.	Adjustment		
Min	Max	øD	øD1	L					Adj. Key	Clamp Key	Locking Key
24	30	22	12	34	D22 75 400	CCMT 0602..	TT 400	0.100	2	T8	3
29	40	27	15	42	D27 75 401	CCMT 0803..	TT 401	0.180	2	T10	4
29	40	27	15	42	D27 75 409	CCMT 09T3..	TT 409	0.180	2	T15	4
39	50	32	20	45	D32 75 401	CCMT 0803..	TT 401	0.260	2.5	T10	4
39	50	32	20	45	D32 75 409	CCMT 09T3..	TT 409	0.260	2.5	T15	4
49	65	42	24	56	D42 75 300	TCMT 16T3..	TT 300	0.600	3	T15	5
49	65	42	24	56	D42 75 402	CCMT 1204..	TT 402	0.600	3	T20	5
53	65	42	24	56	D42 75 402N	CNMG 1204..R	TT 402N	0.600	3	2.5	5
63	82	54	28	66	D54 75 300	TCMT 16T3..	TT 300	1.100	3	T15	6
63	82	54	28	66	D54 75 402	CCMT 1204..	TT 402	1.100	3	T20	6
63	82	54	28	66	D54 75 402N	CNMG 1204..R	TT 402N	1.100	3	2.5	6

ROUGH HEADS 75° APPROACH

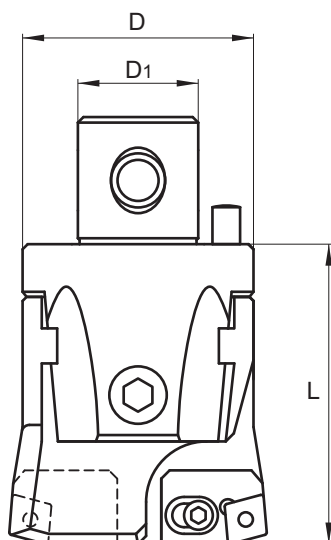

CARTRIDGE TYPE HEADS SYNCHRONIZED ADJUSTMENT

Bore Range		Dimension			Product Number	Cartridge *	Clamp Screw	Kg.	Adjustment		
Min	Max	øD	øD1	L					Adj. Key	Clamp Key	Locking Key
80	102	68	36	86	D68 75 300	2CT 75 300	TT 409	2.300	4	T15	8
80	102	68	36	86	D68 75 402	2CT 75 402	TT 402	2.300	4	T20	8
80	102	68	36	86	D68 75 402N	2CT 75 402N	TT 402N	2.300	4	2.5	8
100	125	85	50	100	D85 75 300	3CT 75 300	TT 300	4.300	5	T15	8
100	125	85	50	100	D85 75 402	3CT 75 402	TT 402	4.300	5	T20	8
100	125	85	50	100	D85 75 402N	3CT 75 402N	TT 402N	4.300	5	2.5	8
125	160	110	60	100	D100 75 300	3CT 75 300	TT 300	6.800	5	T15	8
125	160	110	60	100	D100 75 402	3CT 75 402	TT 402	6.800	5	T20	8
125	160	110	60	100	D100 75 402N	3CT 75 402N	TT 402N	6.800	5	2.5	8
160	220	145	60	100	D200 75 300	3CT 75 300	TT 300	9.000	5	T15	8
160	220	145	60	100	D200 75 402	3CT 75 402	TT 402	9.000	5	T20	8
160	220	145	60	100	D200 75 402N	3CT 75 402N	TT 402N	9.000	5	2.5	8

* FULL CARTRIDGE INFORMATION (INCLUDING INSERT SIZE) IN PAGE 19

ROUGH HEADS 75° APPROACH

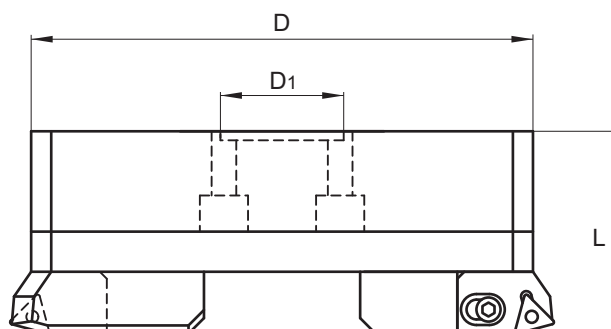

LARGE DIAMETER CARTRIDGE TYPE HEADS SYNCHRONIZED ADJUSTMENT

Bore Range Min Max	Dimension			Product Number	Cartridge *	Clamp Screw	Kg.	Adjustment		
	øD	øD1	L					Adj. Key	Clamp Key	Locking Key
220 320	202	60	90	D300 75 300	3CT 75 300	TT 300	10.100	5	T15	4
220 320	202	60	90	D300 75 402	3CT 75 402	TT 402	10.100	5	T20	4
220 320	202	60	90	D300 75 402N	3CT 75 402N	TT 402N	10.100	5	2.5	4
290 400	272	60	90	D400 75 300	3CT 75 300	TT 300	13.750	5	T15	4
290 400	272	60	90	D400 75 402	3CT 75 402	TT 402	13.750	5	T20	4
290 400	272	60	90	D400 75 402N	3CT 75 402N	TT 402N	13.750	5	2.5	4
370 500	352	60	90	D500 75 300	3CT 75 300	TT 300	16.900	5	T15	4
370 500	352	60	90	D500 75 402	3CT 75 402	TT 402	16.900	5	T20	4
370 500	352	60	90	D500 75 402N	3CT 75 402N	TT 402N	16.900	5	2.5	4

* FULL CARTRIDGE INFORMATION (INCLUDING INSERT SIZE) IN PAGE 19

ROUGH HEADS 90° APPROACH

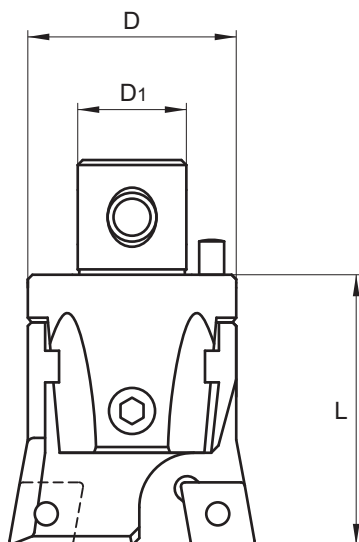

INTEGRAL POCKET TYPE HEADS SYNCHRONIZED ADJUSTMENT

Bore Range		Dimension			Product Number	Insert	Clamp Screw	Kg.	Adjustment		
Min	Max	øD	øD1	L					Adj. Key	Clamp Key	Locking Key
24	30	22	12	34	D22 90 400	CCMT 0602..	TT 400	0.100	2	T8	3
29	40	27	15	42	D27 90 401	CCMT 0803..	TT 401	0.180	2	T10	4
29	40	27	15	42	D27 90 409	CCMT 09T3..	TT 409	0.180	2	T15	4
39	50	32	20	45	D32 90 401	CCMT 0803..	TT 401	0.260	2.5	T10	4
39	50	32	20	45	D32 90 409	CCMT 09T3..	TT 409	0.260	2.5	T15	4
49	65	42	24	56	D42 90 300	TCMT 16T3..	TT 300	0.600	3	T15	5
49	65	42	24	56	D42 90 402	CCMT 1204..	TT 402	0.600	3	T20	5
53	65	42	24	56	D42 90 402N	CNMG 1204..L	TT 402N	0.600	3	2.5	5
63	82	54	28	66	D54 90 300	TCMT 16T3..	TT 300	1.100	3	T15	6
63	82	54	28	66	D54 90 402	CCMT 1204..	TT 402	1.100	3	T20	6
63	82	54	28	66	D54 90 402N	CNMG 1204..L	TT 402N	1.100	3	2.5	6

ROUGH HEADS 90° APPROACH

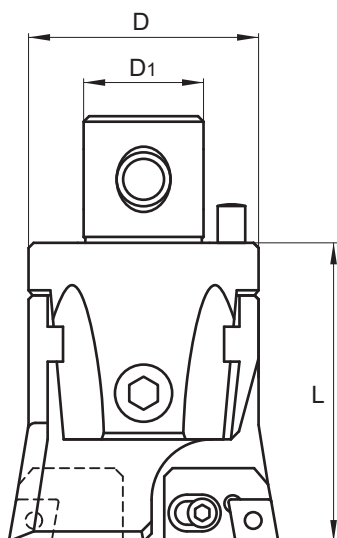

CARTRIDGE TYPE HEADS SYNCHRONIZED ADJUSTMENT

Bore Range		Dimension			Product Number	Cartridge *	Clamp Screw	Kg.	Adjustment		
Min	Max	øD	øD1	L					Adj. Key	Clamp Key	Locking Key
80	102	68	36	86	D68 90 300	2CT 90 300	TT 409	2.300	4	T15	8
80	102	68	36	86	D68 90 402	2CT 90 402	TT 402	2.300	4	T20	8
80	102	68	36	86	D68 90 402N	2CT 90 402N	TT 402N	2.300	4	2.5	8
100	125	85	50	100	D85 90 300	3CT 90 300	TT 300	4.300	5	T15	8
100	125	85	50	100	D85 90 402	3CT 90 402	TT 402	4.300	5	T20	8
100	125	85	50	100	D85 90 402N	3CT 90 402N	TT 402N	4.300	5	2.5	8
125	160	110	60	100	D100 90 300	3CT 90 300	TT 300	6.800	5	T15	8
125	160	110	60	100	D100 90 402	3CT 90 402	TT 402	6.800	5	T20	8
125	160	110	60	100	D100 90 402N	3CT 90 402N	TT 402N	6.800	5	2.5	8
160	220	145	60	100	D200 90 300	3CT 90 300	TT 300	9.000	5	T15	8
160	220	145	60	100	D200 90 402	3CT 90 402	TT 402	9.000	5	T20	8
160	220	145	60	100	D200 90 402N	3CT 90 402N	TT 402N	9.000	5	2.5	8

* FULL CARTRIDGE INFORMATION (INCLUDING INSERT SIZE) IN PAGE 19

ROUGH HEADS 90° APPROACH

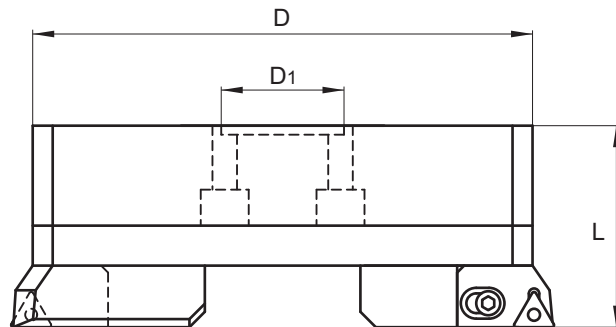

LARGE DIAMETER CARTRIDGE TYPE HEADS SYNCHRONIZED ADJUSTMENT

Bore Range Min Max	Dimension			Product Number	Cartridge *	Clamp Screw	Kg.	Adjustment		
	øD	øD1	L					Adj. Key	Clamp Key	Locking Key
220 320	202	60	90	D300 90 300	3CT 90 300	TT 300	10.100	5	T15	4
220 320	202	60	90	D300 90 402	3CT 90 402	TT 402	10.100	5	T20	4
220 320	202	60	90	D300 90 402N	3CT 90 402N	TT 402N	10.100	5	2.5	4
290 400	272	60	90	D400 90 300	3CT 90 300	TT 300	13.750	5	T15	4
290 400	272	60	90	D400 90 402	3CT 90 402	TT 402	13.750	5	T20	4
290 400	272	60	90	D400 90 402N	3CT 90 402N	TT 402N	13.750	5	2.5	4
370 500	352	60	90	D500 90 300	3CT 90 300	TT 300	16.900	5	T15	4
370 500	352	60	90	D500 90 402	3CT 90 402	TT 402	16.900	5	T20	4
370 500	352	60	90	D500 90 402N	3CT 90 402N	TT 402N	16.900	5	2.5	4

* FULL CARTRIDGE INFORMATION (INCLUDING INSERT SIZE) IN PAGE 19

FINISH HEADS 75° APPROACH

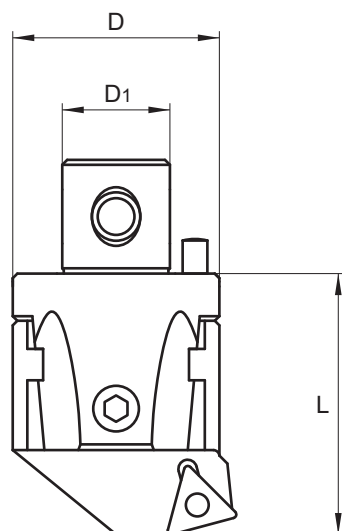

INTEGRAL POCKET TYPE HEADS ADJUSTING ACCURACY 0.002 mm Ø

Bore Range		Dimension			Product Number	Insert	Clamp Screw	Kg.	Adjusting Accuracy		
Min	Max	øD	øD1	L					Adj. Key	Clamp Key	Locking Key
24	30	22	12	34	A22 75 400	CCMT 0602..	TT 400	0.080	2	T8	3
29	40	27	15	42	A27 75 401	CCMT 0803..	TT 401	0.180	2	T10	4
29	40	27	15	42	A27 75 409	CCMT 09T3..	TT 409	0.180	2	T15	4
39	50	32	20	45	A32 75 401	CCMT 0803..	TT 401	0.250	2.5	T10	4
39	50	32	20	45	A32 75 409	CCMT 09T3..	TT 409	0.250	2.5	T15	4
49	65	42	24	56	A42 75 300	TCMT 16T3..	TT 300	0.580	3	T15	5
63	82	54	28	66	A54 75 300	TCMT 16T3..	TT 300	1.050	3	T15	6

FINISH HEADS 75° APPROACH

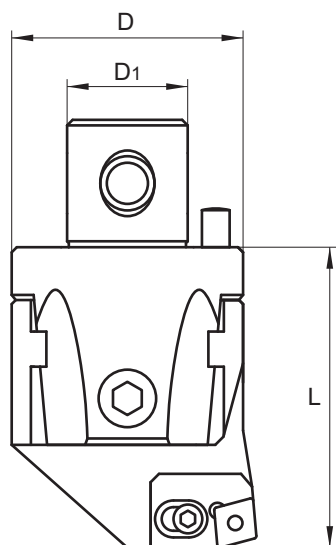

CARTRIDGE TYPE HEADS ADJUSTING ACCURACY 0.002 mm Ø

Bore Range		Dimension			Product Number	Cartridge *	Clamp Screw	Kg.	Adjusting Accuracy		
Min	Max	øD	øD1	L					Adj. Key	Clamp Key	Locking Key
80	102	68	36	86	A68 75 300	2CT 75 300	TT 409	2.175	5	T15	8
80	102	68	36	86	A68 75 402	2CT 75 402	TT 402	2.175	5	T20	8
80	102	68	36	86	A68 75 402N	2CT 75 402N	TT 402N	2.175	5	2.5	8
100	125	85	50	100	A85 75 300	3CT 75 300	TT 300	4.200	6	T15	8
100	125	85	50	100	A85 75 402	3CT 75 402	TT 402	4.200	6	T20	8
100	125	85	50	100	A85 75 402N	3CT 75 402N	TT 402N	4.200	6	2.5	8
125	160	110	60	100	A100 75 300	3CT 75 300	TT 300	6.600	6	T15	8
125	160	110	60	100	A100 75 402	3CT 75 402	TT 402	6.600	6	T20	8
125	160	110	60	100	A100 75 402N	3CT 75 402N	TT 402N	6.600	6	2.5	8
160	220	145	60	100	A200 75 300	3CT 75 300	TT 300	8.960	6	T15	8
160	220	145	60	100	A200 75 402	3CT 75 402	TT 402	8.960	6	T20	8
160	220	145	60	100	A200 75 402N	3CT 75 402N	TT 402N	8.960	6	2.5	8

* FULL CARTRIDGE INFORMATION (INCLUDING INSERT SIZE) IN PAGE 19

FINISH HEADS 75° APPROACH

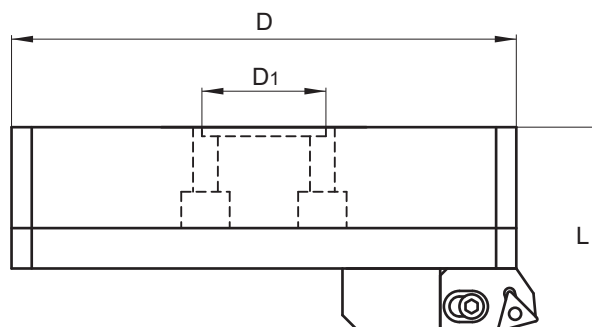

LARGE DIAMETER CARTRIDGE TYPE HEADS ADJUSTING ACCURACY 0.002 mm Ø

Bore Range Min Max	Dimension			Product Number	Cartridge *	Clamp Screw	Kg.	Adjusting Accuracy		
	øD	øD1	L					Adj. Key	Clamp Key	Locking Key
220 320	202	60	90	A300 75 300	3CT 75 300	TT 300	9.300	5	T15	4
220 320	202	60	90	A300 75 402	3CT 75 402	TT 402	9.300	5	T20	4
220 320	202	60	90	A300 75 402N	3CT 75 402N	TT 402N	9.300	5	2.5	4
290 400	272	60	90	A400 75 300	3CT 75 300	TT 300	12.950	5	T15	4
290 400	272	60	90	A400 75 402	3CT 75 402	TT 402	12.950	5	T20	4
290 400	272	60	90	A400 75 402N	3CT 75 402N	TT 402N	12.950	5	2.5	4
370 500	352	60	90	A500 75 300	3CT 75 300	TT 300	16.250	5	T15	4
370 500	352	60	90	A500 75 402	3CT 75 402	TT 402	16.250	5	T20	4
370 500	352	60	90	A500 75 402N	3CT 75 402N	TT 402N	16.250	5	2.5	4

* FULL CARTRIDGE INFORMATION (INCLUDING INSERT SIZE) IN PAGE 19

FINISH HEADS 90° APPROACH

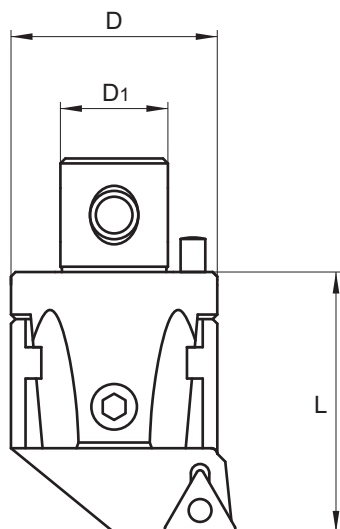

INTEGRAL POCKET TYPE HEADS ADJUSTING ACCURACY 0.002 mm Ø

Bore Range		Dimension			Product Number	Insert	Clamp Screw	Kg.	Adjusting Accuracy		
Min	Max	øD	øD1	L					Adj. Key	Clamp Key	Locking Key
24	30	22	12	34	A22 90 400	CCMT 0602..	TT 400	0.080	2	T8	3
29	40	27	15	42	A27 90 401	CCMT 0803..	TT 401	0.180	2	T10	4
29	40	27	15	42	A27 90 409	CCMT 09T3..	TT 409	0.180	2	T15	4
39	50	32	20	45	A32 90 300	TCMT 16T3..	TT 300	0.250	2.5	T15	4
39	50	32	20	45	A32 90 401	CCMT 0803..	TT 401	0.250	2.5	T10	4
39	50	32	20	45	A32 90 409	CCMT 09T3..	TT 409	0.250	2.5	T15	4
49	65	42	24	56	A42 90 300	TCMT 16T3..	TT 300	0.580	3	T15	5
49	65	42	24	56	A42 90 402	CCMT 1204..	TT 402	0.580	3	T20	5
53	65	42	24	56	A42 90 402N	CNMG 1204..L	TT 402N	0.580	3	2.5	5
63	82	54	28	66	A54 90 300	TCMT 16T3..	TT 300	1.050	3	T15	6
63	82	54	28	66	A54 90 402	CCMT 1204..	TT 402	1.050	3	T20	6
63	82	54	28	66	A54 90 402N	CNMG 1204..L	TT 402N	1.050	3	2.5	6

FINISH HEADS 90° APPROACH

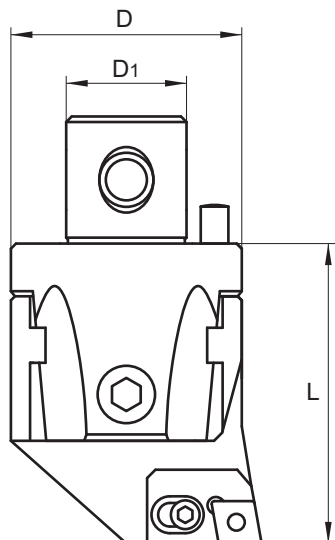

CARTRIDGE TYPE HEADS ADJUSTING ACCURACY 0.002 mm Ø

Bore Range		Dimension			Product Number	Cartridge *	Clamp Screw	Kg.	Adjusting Accuracy		
Min	Max	øD	øD1	L					Adj. Key	Clamp Key	Locking Key
80	102	68	36	86	A68 90 300	2CT 90 300	TT 409	2.175	5	T15	8
80	102	68	36	86	A68 90 402	2CT 90 402	TT 402	2.175	5	T20	8
80	102	68	36	86	A68 90 402N	2CT 90 402N	TT 402N	2.175	5	2.5	8
100	125	85	50	100	A85 90 300	3CT 90 300	TT 300	4.200	6	T15	8
100	125	85	50	100	A85 90 402	3CT 90 402	TT 402	4.200	6	T20	8
100	125	85	50	100	A85 90 402N	3CT 90 402N	TT 402N	4.200	6	2.5	8
125	160	110	60	100	A100 90 300	3CT 90 300	TT 300	6.600	6	T15	8
125	160	110	60	100	A100 90 402	3CT 90 402	TT 402	6.600	6	T20	8
125	160	110	60	100	A100 90 402N	3CT 90 402N	TT 402N	6.600	6	2.5	8
160	220	145	60	100	A200 90 300	3CT 90 300	TT 300	8.960	6	T15	8
160	220	145	60	100	A200 90 402	3CT 90 402	TT 402	8.960	6	T20	8
160	220	145	60	100	A200 90 402N	3CT 90 402N	TT 402N	8.960	6	2.5	8

* FULL CARTRIDGE INFORMATION (INCLUDING INSERT SIZE) IN PAGE 19

FINISH HEADS 90° APPROACH

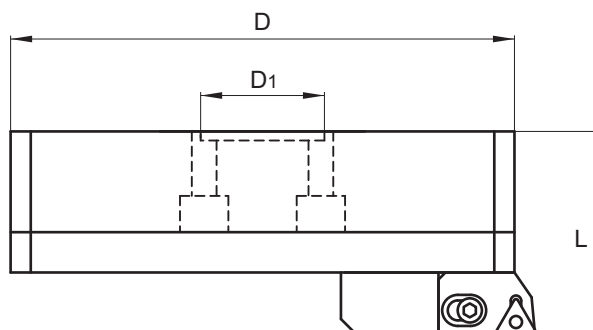

LARGE DIAMETER CARTRIDGE TYPE HEADS ADJUSTING ACCURACY 0.002 mm Ø

Bore Range		Dimension			Product Number	Cartridge *	Clamp Screw	Kg.	Adjusting Accuracy		
Min	Max	øD	øD1	L					Adj. Key	Clamp Key	Locking Key
220	320	202	60	90	A300 90 300	3CT 90 300	TT 300	9.300	5	T15	4
220	320	202	60	90	A300 90 402	3CT 90 402	TT 402	9.300	5	T20	4
220	320	202	60	90	A300 90 402N	3CT 90 402N	TT 402N	9.300	5	2.5	4
290	400	272	60	90	A400 90 300	3CT 90 300	TT 300	12.950	5	T15	4
290	400	272	60	90	A400 90 402	3CT 90 402	TT 402	12.950	5	T20	4
290	400	272	60	90	A400 90 402N	3CT 90 402N	TT 402N	12.950	5	2.5	4
370	500	352	60	90	A500 90 300	3CT 90 300	TT 300	16.250	5	T15	4
370	500	352	60	90	A500 90 402	3CT 90 402	TT 402	16.250	5	T20	4
370	500	352	60	90	A500 90 402N	3CT 90 402N	TT 402N	16.250	5	2.5	4

* FULL CARTRIDGE INFORMATION (INCLUDING INSERT SIZE) IN PAGE 19

MICRO BORING HEADS

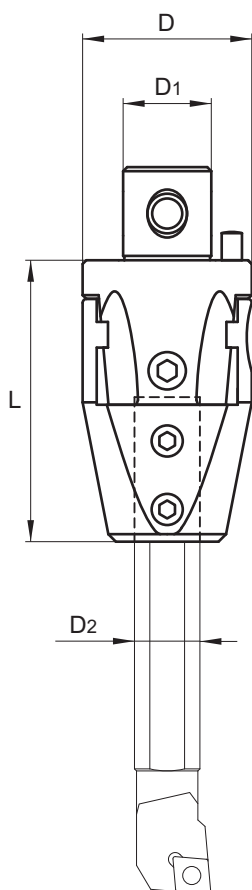

HEADS FOR ISO BORING BARS ADJUSTING ACCURACY 0.002 mm Ø

Bore Range		Dimension				Product Number	Kg.	Adj. Key / Locking Key	
Min	Max	øD	øD1	øD2	L			Adj. Key	Locking Key
8	20	27	15	6	50	A 27 006	0.180	2	4
10	21	27	15	8	50	A 27 008	0.180	2	4
10	21	32	20	8	58	A 32 008	0.370	2.5	4
13	25	32	20	10	58	A 32 010	0.370	2.5	4
13	29	42	24	10	70	A 42 010	0.690	3	5
16	34	42	24	12	70	A 42 012	0.690	3	5
20	38	42	24	16	70	A 42 016	0.690	3	5

ISO BORING BARS

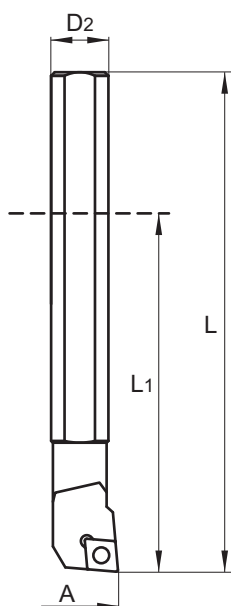

STEEL SHANK BORING BARS

Dimension				ISO Boring bar	Insert	Clamp Screw	Clamp Key
øD2	øA	L	L1				
6	8	70	46	S06E SELPR 04	EPGT 0401..L	M2X4	T6
6	8	70	46	S06E SELPR 05	EPMT 0502..	M2.2X5.6	T7
8	10	80	50	S08F SCLCR 06	CCMT 0602..	M2.5X5.8	T7
10	13	90	54	S10G SCLCR 06	CCMT 0602..	M2.5X5.8	T7
12	16	100	64	S12H SCLCR 06	CCMT 0602..	M2.5X5.8	T7
16	20	110	74	S16J SCLCR 09	CCMT 09T3..	M4X8.5	T15
16	20	110	74	S16J STFCR 09	TCMT 0902..	M2.2X6.4	T7
16	20	110	74	S16J STFCR 16	TCMT 16T3..	M4X8.5	T15

CARBIDE SHANK BORING BARS

Dimension				ISO Boring bar	Insert	Clamp Screw	Clamp Key
øD2	øA	L	L1				
6	8	80	56	C06F SELPR 04	EPGT 0401..L	M2X4	T6
8	10	90	60	C08G SCLCR 06	CCMT 0602..	M2.5X5.8	T7
10	13	110	74	C10J SCLCR 06	CCMT 0602..	M2.5X5.8	T7
12	16	125	89	C12K SCLCR 06	CCMT 0602..	M2.5X5.8	T7
16	20	140	104	C16L SCLCR 09	CCMT 09T3..	M4X8.5	T15

INDEXABLE BORING BARS FOR A 42 016

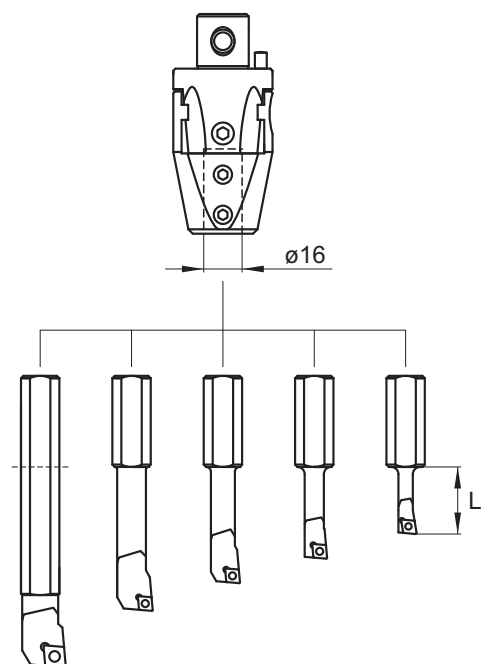

RHOMBIC INSERT

Bore Range		L	Product Number	Insert	Clamp Screw	Clamp Key
Min	Max					
6	24	20	S05/16 SELPR 04	EPGT 0401 .. L	M2X3.3	T6
8	26	25	S06/16 SELPR 04	EPGT 0401 .. L	M2X4	T6
8	26	25	S06/16 SELPR 05	EPMT 0502 ..	M2.2X5.6	T7
10	28	35	S08/16 SCLCR 06	CCMT 0602 ..	M2.5X4.8	T8
13	31	45	S10/16 SCLCR 06	CCMT 0602 ..	M2.5X6	T8
16	34	57	S12/16 SCLCR 06	CCMT 0602 ..	M2.5X6.8	T8
20	38	73	S16/16 SCLCR 09	CCMT 09T3 ..	M4X8.5	T15

TRIANGULAR INSERT

Bore Range		L	Product Number	Insert	Clamp Screw	Clamp Key
Min	Max					
8	26	25	S06/16 STFCR 06	TCMT 06T1 ..	M2X4.9	T6
10	28	35	S08/16 STFCR 06	TCMT 06T1 ..	M2X4.9	T6
13	31	45	S10/16 STFCR 09	TCMT 0902 ..	M2.2X6.4	T7
16	34	57	S12/16 STFCR 09	TCMT 0902 ..	M2.2X6.4	T7
20	38	73	S16/16 STFCR 09	TCMT 0902 ..	M2.2X6.4	T7
20	38	73	S16/16 STFCR 16	TCMT 16T3 ..	M4X8.5	T15

INDEXABLE STANDARD CARTRIDGES

SYMETRICAL BORING

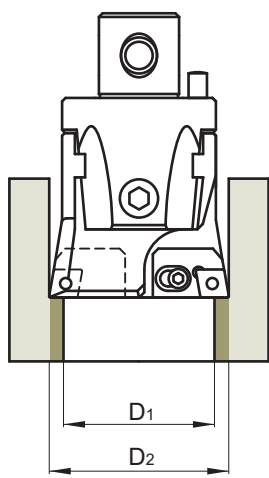

2CT ... + 2CT ...
or
3CT ... + 3CT ...

STAGGERED BORING

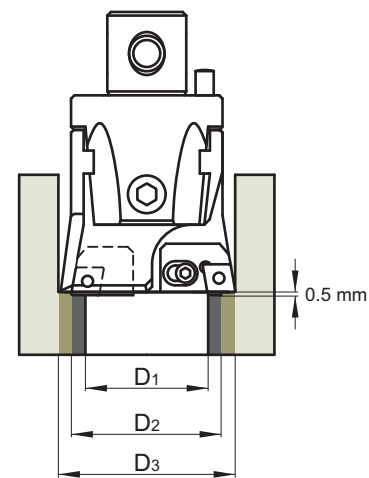

2CT ... + 2CT ... S
or
3CT ... + 3CT ... S

TYPE 90 300

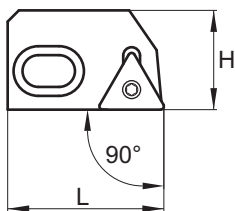

TYPE 75 300

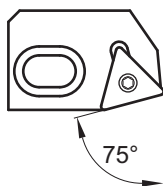

TYPE 90 402

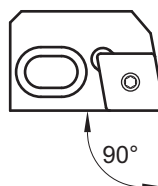

TYPE 75 402

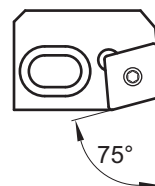

Product Number	Dimension		Kg.	Insert	1	2	3	4	5	6	7
	H	L									
2CT 75 300	22.5	35	0.050	TCMT 16T3..	D 68 29	A 68 26	D 68 28	5	2	TT 409	T15
2CT 75 402	22.5	35	0.050	CCMT 1204..	D 68 29	A 68 26	D 68 28	5	2	TT 402	T20
2CT 75 402 N	22.5	35	0.050	CNMG 1204..R	D 68 29	A 68 26	D 68 28	5	2	TT 402N	2.5
2CT 90 300	22.5	35	0.050	TCMT 16T3..	D 68 29	A 68 26	D 68 28	5	2	TT 409	T15
2CT 90 300 S	23	33	0.050	TCMT 16T3..	D 68 29	A 68 26	D 68 28	5	2	TT 409	T15
2CT 90 402	22.5	35	0.050	CCMT 1204..	D 68 29	A 68 26	D 68 28	5	2	TT 402	T20
2CT 90 402 S	23	33	0.050	CCMT 1204..	D 68 29	A 68 26	D 68 28	5	2	TT 402	T20
2CT 90 402 N	22.5	35	0.050	CNMG 1204..L	D 68 29	A 68 26	D 68 28	5	2	TT 402N	2.5
2CT 90 402 NS	23	33	0.050	CNMG 1204..L	D 68 29	A 68 26	D 68 28	5	2	TT 402N	2.5
3CT 75 300	28	39	0.100	TCMT 16T3..	D 85 29	D 85 27	D 68 28	5	3	TT 300	T15
3CT 75 402	28	39	0.100	CCMT 1204..	D 85 29	D 85 27	D 68 28	5	3	TT 402	T20
3CT 75 402 N	28	39	0.100	CNMG 1204..R	D 85 29	D 85 27	D 68 28	5	3	TT 402N	2.5
3CT 90 300	28	39	0.100	TCMT 16T3..	D 85 29	D 85 27	D 68 28	5	3	TT 300	T15
3CT 90 300 S	28.5	37	0.100	TCMT 16T3..	D 85 29	D 85 27	D 68 28	5	3	TT 300	T15
3CT 90 402	28	39	0.100	CCMT 1204..	D 85 29	D 85 27	D 68 28	5	3	TT 402	T20
3CT 90 402 S	28.5	37	0.100	CCMT 1204..	D 85 29	D 85 27	D 68 28	5	3	TT 402	T20
3CT 90 402 N	28	39	0.100	CNMG 1204..L	D 85 29	D 85 27	D 68 28	5	3	TT 402N	2.5
3CT 90 402 NS	28.5	37	0.100	CNMG 1204..L	D 85 29	D 85 27	D 68 28	5	3	TT 402N	2.5

INDEXABLE SPECIAL CARTRIDGES

TYPE GR 300

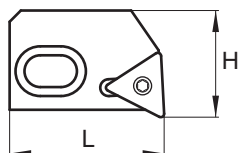

TYPE GR 411



TYPE 30 300

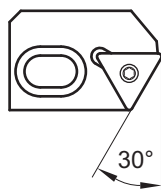

TYPE 45 300

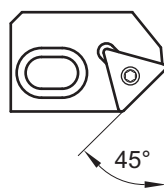

TYPE 85 502

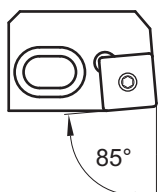

TYPE W06 / W08

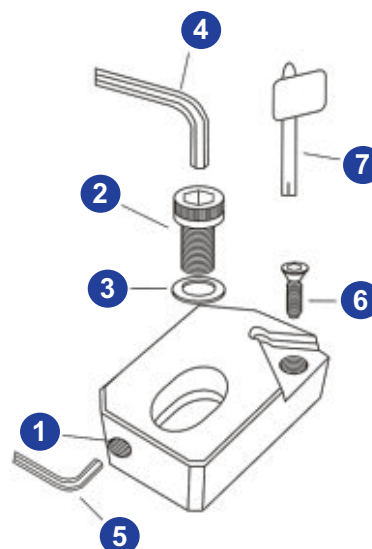

Product Number	Dimension		Kg.	Insert	1	2	3	4	5	6	7
	H	L									
2CT GR 300	25	36	0.050	TCMT 16T3..	D 68 29	A 68 26	D 68 28	5	2	TT 409	T15
2CT GR 411	25	36	0.050	DCMT 11T3..	D 68 29	A 68 26	D 68 28	5	2	TT 409	T15
2CT 30 300	22.5	35	0.050	TCMT 16T3..	D 68 29	A 68 26	D 68 28	5	2	TT 409	T15
2CT 45 300	22.5	35	0.050	TCMT 16T3..	D 68 29	A 68 26	D 68 28	5	2	TT 409	T15
2CT 85 502	22.5	35	0.050	SCMT 1204..	D 68 29	A 68 26	D 68 28	5	2	TT 402	T20
2CT 90 W06	23.5	35	0.050	WCMT 06T3..	D 68 29	A 68 26	D 68 28	5	2	M3.5X5	T9
2CT 90 W06 S	24	33	0.050	WCMT 06T3..	D 68 29	A 68 26	D 68 28	5	2	M3.5X5	T9
3CT GR 300	30	40	0.100	TCMT 16T3..	D 85 29	D 85 27	D 68 28	5	3	TT 300	T15
3CT GR 411	30	40	0.100	DCMT 11T3..	D 85 29	D 85 27	D 68 28	5	3	TT 300	T15
3CT 30 300	28	39	0.100	TCMT 16T3..	D 85 29	D 85 27	D 68 28	5	3	TT 300	T15
3CT 45 300	28	39	0.100	TCMT 16T3..	D 85 29	D 85 27	D 68 28	5	3	TT 300	T15
3CT 85 502	28	39	0.100	SCMT 1204..	D 85 29	D 85 27	D 68 28	5	3	TT 402	T20
3CT 90 W08	29	39	0.100	WCMT 0804..	D 85 29	D 85 27	D 68 28	5	3	M4X5.5	T15
3CT 90 W08 S	29.5	37	0.100	WCMT 0804..	D 85 29	D 85 27	D 68 28	5	3	M4X5.5	T15

ARBORS FOR BORING HEADS

MAS BT 403

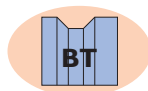

ISO 30

Dimension					Product Number	Kg.	Coupling Screw
øD	øD1	L	L1	PM			
22	12	125	91	100	BT 330 22 100	0.580	22-68
27	15	77	35	55	BT 330 27 55	0.450	27-610
27	15	125	83	100	BT 330 27 100	0.640	27-610
32	20	83	38	60	BT 330 32 60	0.450	32-810
32	20	125	80	100	BT 330 32 100	0.690	32-810
42	24	100	44	75	BT 330 42 75	0.550	42-1014

ISO 40

Dimension					Product Number	Kg.	Coupling Screw
øD	øD1	L	L1	PM			
22	12	80	46	50	BT 340 22 50	1.200	22-68
22	12	110	76	80	BT 340 22 80	1.300	22-68
22	12	130	96	100	BT 340 22 100	1.390	22-68
27	15	82	40	55	BT 340 27 55	1.200	27-610
27	15	130	88	100	BT 340 27 100	1.450	27-610
27	15	160	118	130	BT 340 27 130	1.600	27-610
32	20	88	43	60	BT 340 32 60	1.200	32-810
32	20	130	85	100	BT 340 32 100	1.470	32-810
32	20	160	115	130	BT 340 32 130	1.700	32-810
42	24	104	48	75	BT 340 42 75	1.300	42-1014
42	24	190	134	160	BT 340 42 160	2.250	42-1014
42	24	230	174	200	BT 340 42 200	2.750	42-1014
54	28	120	54	90	BT 340 54 90	1.800	54-1220
54	28	190	124	160	BT 340 54 160	2.800	54-1220
54	28	230	164	200	BT 340 54 200	3.550	54-1220
68	36	181	95	160	BT 340 68 160	2.800	68-1624
68	36	221	135	200	BT 340 68 200	3.900	68-1624
85	50	220	120	200	BT 340 85 200	5.900	85-1630
100	60	220	120	200	BT 340 100 200	6.200	100-2035

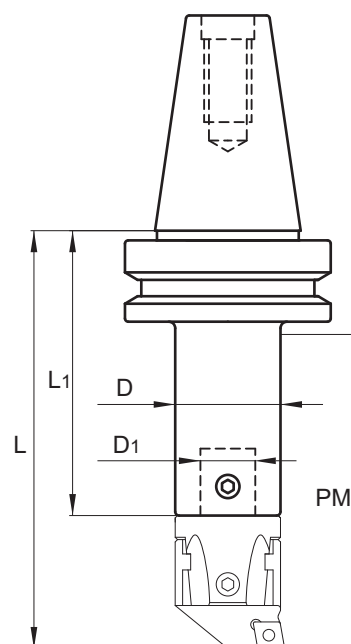

ARBORS FOR BORING HEADS

MAS BT 403

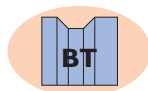

ISO 45 (UPON REQUEST)

Dimension					Product Number	Kg.	Coupling Screw
øD	øD1	L	L1	PM			
22	12	116	82	80	BT 345 22 80	2.550	22-68
22	12	136	102	100	BT 345 22 100	2.610	22-68
27	15	88	46	55	BT 345 27 55	2.550	27-610
27	15	136	94	100	BT 345 27 100	2.750	27-610
27	15	166	124	130	BT 345 27 130	2.800	27-610
32	20	94	49	60	BT 345 32 60	2.550	32-810
32	20	166	121	130	BT 345 32 130	2.950	32-810
32	20	196	151	160	BT 345 32 160	3.200	32-810
42	24	110	54	75	BT 345 42 75	2.650	42-1014
42	24	196	140	160	BT 345 42 160	3.500	42-1014
42	24	236	180	200	BT 345 42 200	4.000	42-1014
54	28	123	57	90	BT 345 54 90	2.850	54-1220
54	28	196	130	160	BT 345 54 160	4.100	54-1220
54	28	236	170	200	BT 345 54 200	4.800	54-1220
68	36	237	151	200	BT 345 68 200	5.550	68-1624
68	36	297	211	260	BT 345 68 260	7.250	68-1624
85	50	236	136	200	BT 345 85 200	6.100	85-1630
85	50	296	196	260	BT 345 85 260	8.850	85-1630
85	50	356	256	320	BT 345 85 320	11.650	85-1630

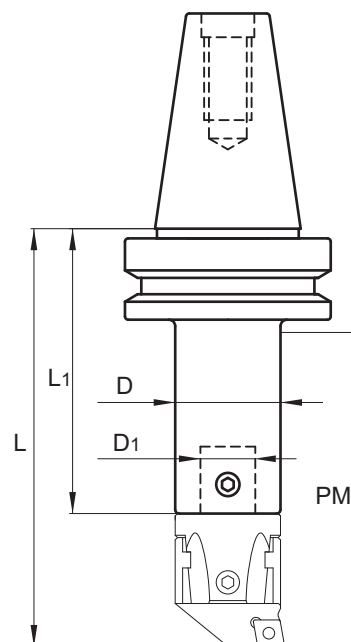

ARBORS FOR BORING HEADS

MAS BT 403

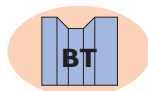

ISO 50



Dimension					Product Number	Kg.	Coupling Screw	
øD	øD1	L	L1	PM				
22	12	121	87	80	BT 350 22 80	4.200	22-68	
22	12	141	107	100	BT 350 22 100	4.350	22-68	
27	15	93	51	55	BT 350 27 55	4.050	27-610	
27	15	141	99	100	BT 350 27 100	4.400	27-610	
27	15	171	129	130	BT 350 27 130	4.500	27-610	
32	20	99	54	60	BT 350 32 60	3.950	32-810	
32	20	171	126	130	BT 350 32 130	4.600	32-810	
32	20	201	156	160	BT 350 32 160	4.800	32-810	
42	24	115	59	75	BT 350 42 75	4.150	42-1014	
42	24	201	145	160	BT 350 42 160	5.200	42-1014	
42	24	241	185	200	BT 350 42 200	5.800	42-1014	
54	28	131	65	90	BT 350 54 90	4.800	54-1220	
54	28	201	135	160	BT 350 54 160	5.800	54-1220	
54	28	241	175	200	BT 350 54 200	6.500	54-1220	
68	36	154	68	115	BT 350 68 115	4.450	68-1624	
68	36	242	156	200	BT 350 68 200	7.200	68-1624	
68	36	302	216	260	BT 350 68 260	8.850	68-1624	
85	50	242	142	200	BT 350 85 200	7.850	85-1630	
85	50	302	202	260	BT 350 85 260	10.650	85-1630	
85	50	362	262	320	BT 350 85 320	13.400	85-1630	
*	100	60	195	95	170	BT 350 100 170	6.150	100-2035
*	100	60	302	202	260	BT 350 100 260	12.850	100-2035
*	100	60	362	262	320	BT 350 100 320	16.500	100-2035
*	100	60	160	70	125	BT 550 160	6.250	M12X40

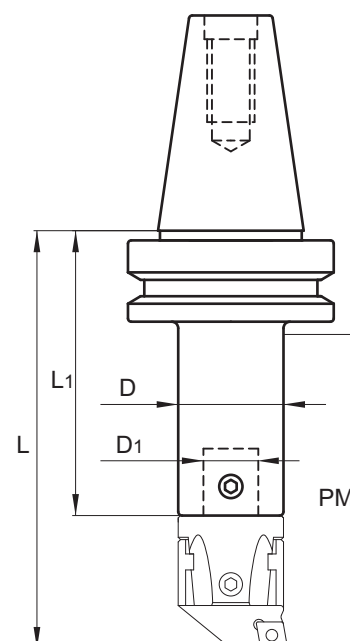

* ALSO FOR HEADS Ø200

* SEE PAGE 38: THE ASSEMBLY SYSTEM FOR LARGE BORING HEADS

ARBORS FOR BORING HEADS

DIN 69871

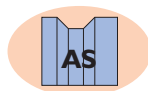

ISO 30

Dimension					Product Number	Kg.	Coupling Screw
øD	øD1	L	L1	PM			
22	12	138	104	100	AS 330 22 100	0.640	22-68
27	15	90	48	55	AS 330 27 55	0.480	27-610
27	15	138	96	100	AS 330 27 100	0.690	27-610
32	20	96	51	60	AS 330 32 60	0.390	32-810
32	20	138	93	100	AS 330 32 100	0.650	32-810

ISO 40

Dimension					Product Number	Kg.	Coupling Screw
øD	øD1	L	L1	PM			
22	12	118	84	80	AS 340 22 80	1.350	22-68
22	12	138	104	100	AS 340 22 100	1.450	22-68
27	15	90	48	55	AS 340 27 55	1.250	27-610
27	15	138	96	100	AS 340 27 100	1.500	27-610
27	15	168	126	130	AS 340 27 130	1.600	27-610
32	20	96	51	60	AS 340 32 60	1.250	32-810
32	20	138	93	100	AS 340 32 100	1.500	32-810
32	20	168	123	130	AS 340 32 130	1.750	32-810
42	24	112	56	75	AS 340 42 75	1.300	42-1014
42	24	182	126	160	AS 340 42 160	2.100	42-1014
42	24	222	166	200	AS 340 42 200	2.600	42-1014
54	28	142	76	120	AS 340 54 120	1.850	54-1220
54	28	182	116	160	AS 340 54 160	2.450	54-1220
54	28	222	156	200	AS 340 54 200	3.150	54-1220
68	36	183	97	160	AS 340 68 160	2.500	68-1624
68	36	223	137	200	AS 340 68 200	3.650	68-1624
85	50	224	124	200	AS 340 85 200	5.650	85-1630
100	60	224	124	200	AS 340 100 200	5.950	100-2035

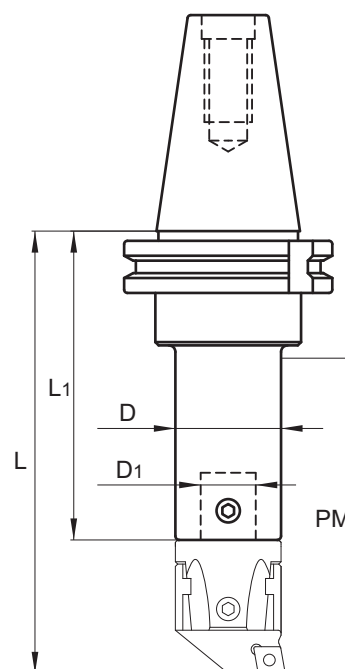

ARBORS FOR BORING HEADS

DIN 69871

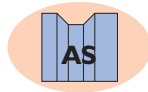

ISO 45 (UPON REQUEST)

Dimension					Product Number	Kg.	Coupling Screw
øD	øD1	L	L1	PM			
22	12	118	84	80	AS 345 22 80	2.250	22-68
22	12	138	104	100	AS 345 22 100	2.350	22-68
27	15	90	48	55	AS 345 27 55	1.750	27-610
27	15	138	96	100	AS 345 27 100	2.400	27-610
27	15	168	126	130	AS 345 27 130	2.600	27-610
32	20	96	51	60	AS 345 32 60	1.800	32-810
32	20	168	123	130	AS 345 32 130	2.850	32-810
32	20	198	153	160	AS 345 32 160	3.100	32-810
42	24	112	56	75	AS 345 42 75	1.900	42-1014
42	24	198	142	160	AS 345 42 160	3.000	42-1014
42	24	238	182	200	AS 345 42 200	3.300	42-1014
54	28	125	59	90	AS 345 54 90	2.400	54-1220
54	28	182	116	160	AS 345 54 160	3.900	54-1220
54	28	222	156	200	AS 345 54 200	4.650	54-1220
68	36	223	137	200	AS 345 68 200	4.800	68-1624
68	36	283	197	260	AS 345 68 260	6.650	68-1624
85	50	224	124	200	AS 345 85 200	5.400	85-1630
85	50	284	184	260	AS 345 85 260	8.150	85-1630
85	50	344	244	320	AS 345 85 320	8.900	85-1630

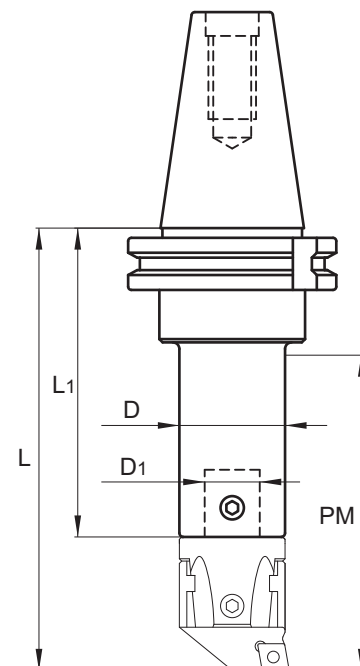

ARBORS FOR BORING HEADS

DIN 69871

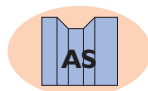

ISO 50

Dimension					Product Number	Kg.	Coupling Screw
øD	øD1	L	L1	PM			
22	12	118	84	80	AS 350 22 80	3.200	22-68
22	12	138	104	100	AS 350 22 100	3.750	22-68
27	15	90	48	55	AS 350 27 55	3.150	27-610
27	15	138	96	100	AS 350 27 100	3.300	27-610
27	15	168	126	130	AS 350 27 130	3.450	27-610
32	20	96	51	60	AS 350 32 60	3.500	32-810
32	20	168	123	130	AS 350 32 130	4.100	32-810
32	20	198	153	160	AS 350 32 160	4.350	32-810
42	24	112	56	75	AS 350 42 75	3.600	42-1014
42	24	198	142	160	AS 350 42 160	4.600	42-1014
42	24	238	182	200	AS 350 42 200	5.150	42-1014
54	28	128	62	90	AS 350 54 90	4.100	54-1220
54	28	198	132	160	AS 350 54 160	5.100	54-1220
54	28	238	172	200	AS 350 54 200	5.950	54-1220
68	36	151	65	115	AS 350 68 115	3.500	68-1624
68	36	223	137	200	AS 350 68 200	6.100	68-1624
68	36	283	197	260	AS 350 68 260	7.800	68-1624
85	50	224	124	200	AS 350 85 200	6.700	85-1630
85	50	284	184	260	AS 350 85 260	9.400	85-1630
85	50	344	244	320	AS 350 85 320	12.000	85-1630
*	100	60	214	114	AS 350 100 190	6.600	100-2035
*	100	60	284	184	AS 350 100 260	10.900	100-2035
*	100	60	344	244	AS 350 100 320	14.600	100-2035
*	100	60	160	70	AS 550 160	6.000	M12X40

* ALSO FOR HEADS Ø200

* SEE PAGE 38: THE ASSEMBLY SYSTEM FOR LARGE BORING HEADS

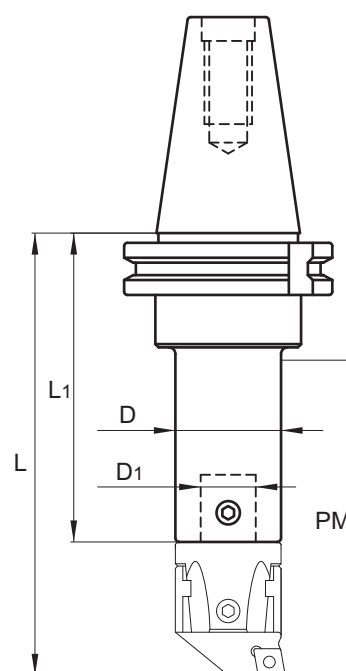

ARBORS FOR BORING HEADS

DIN 2080

OTT

ISO 30

Dimension					Product Number	Kg.	Coupling Screw
øD	øD1	L	L1	PM			
22	12	113	79	100	OTT 330 22 100	0.500	22-68
27	15	65	23	55	OTT 330 27 55	0.340	27-610
27	15	113	71	100	OTT 330 27 100	0.550	27-610
32	20	71	26	60	OTT 330 32 60	0.340	32-810
32	20	113	68	100	OTT 330 32 100	0.610	32-810
42	24	87	31	75	OTT 330 42 75	0.450	42-1014

ISO 40

Dimension					Product Number	Kg.	Coupling Screw
øD	øD1	L	L1	PM			
22	12	95	61	80	OTT 340 22 80	1.100	22-68
22	12	115	81	100	OTT 340 22 100	1.150	22-68
27	15	67	25	55	OTT 340 27 55	1.000	27-610
27	15	115	73	100	OTT 340 27 100	1.250	27-610
27	15	145	103	130	OTT 340 27 130	1.350	27-610
32	20	73	28	60	OTT 340 32 60	1.000	32-810
32	20	115	70	100	OTT 340 32 100	1.250	32-810
32	20	145	100	130	OTT 340 32 130	1.350	32-810
42	24	89	33	75	OTT 340 42 75	1.050	42-1014
42	24	175	119	160	OTT 340 42 160	2.000	42-1014
42	24	215	159	200	OTT 340 42 200	2.500	42-1014
54	28	105	39	90	OTT 340 54 90	1.450	54-1220
54	28	175	109	160	OTT 340 54 160	2.450	54-1220
54	28	215	149	200	OTT 340 54 200	3.400	54-1220
68	36	176	90	160	OTT 340 68 160	2.450	68-1624
68	36	216	130	200	OTT 340 68 200	3.850	68-1624
85	50	211	111	200	OTT 340 85 200	5.650	85-1630
100	60	211	111	200	OTT 340 100 200	5.950	100-2035

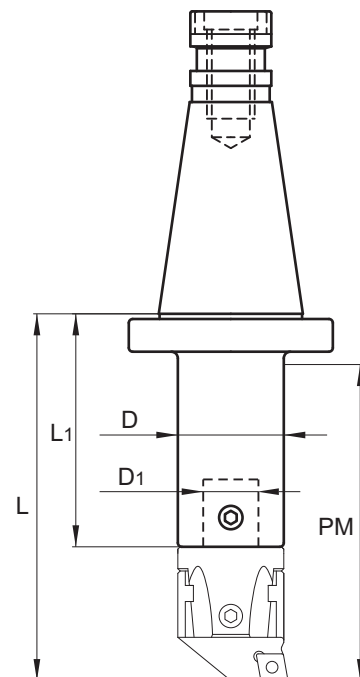

ARBORS FOR BORING HEADS

DIN 2080

OTT

ISO 50

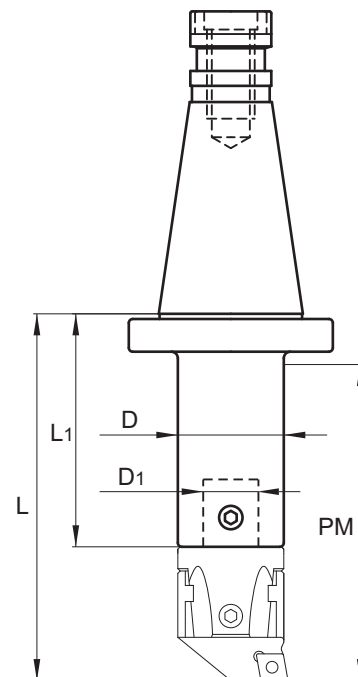

Dimension					Product Number	Kg.	Coupling Screw
øD	øD1	L	L1	PM			
22	12	99	65	80	OTT 350 22 80	3.250	22-68
22	12	119	85	100	OTT 350 22 100	3.350	22-68
27	15	71	29	55	OTT 350 27 55	3.050	27-610
27	15	119	77	100	OTT 350 27 100	3.400	27-610
27	15	149	107	130	OTT 350 27 130	3.500	27-610
32	20	77	32	60	OTT 350 32 60	3.050	32-810
32	20	149	104	130	OTT 350 32 130	3.650	32-810
32	20	179	134	160	OTT 350 32 160	4.000	32-810
42	24	93	37	75	OTT 350 42 75	3.150	42-1014
42	24	179	123	160	OTT 350 42 160	4.200	42-1014
42	24	219	163	200	OTT 350 42 200	4.650	42-1014
54	28	109	43	90	OTT 350 54 90	3.150	54-1220
54	28	179	113	160	OTT 350 54 160	5.400	54-1220
54	28	219	153	200	OTT 350 54 200	6.000	54-1220
68	36	132	46	115	OTT 350 68 115	3.350	68-1624
68	36	220	134	200	OTT 350 68 200	6.100	68-1624
68	36	280	194	260	OTT 350 68 260	7.900	68-1624
85	50	221	121	200	OTT 350 85 200	7.200	85-1630
85	50	281	181	260	OTT 350 85 260	9.900	85-1630
85	50	341	241	320	OTT 350 85 320	12.400	85-1630
*	100	60	193	93	OTT 350 100 170	6.000	100-2035
*	100	60	281	181	OTT 350 100 260	11.300	100-2035
*	100	60	341	241	OTT 350 100 320	16.050	100-2035
*	100	60	160	70	OTT 550 160	6.150	M12X40

* ALSO FOR HEADS Ø200

* SEE PAGE 38: THE ASSEMBLY SYSTEM FOR LARGE BORING HEADS

ARBORS FOR BORING HEADS

DIN 69893



HSK 50

Dimension					Product Number	Kg.	Coupling Screw
øD	øD1	L	L1	PM			
22	12	81	47	55	HSK 50A 22 55	0.500	22-68
27	15	91	49	65	HSK 50A 27 65	0.600	27-610
32	20	101	56	75	HSK 50A 32 75	0.700	32-810
42	24	116	60	90	HSK 50A 42 90	0.900	42-1014



HSK 63

Dimension					Product Number	Kg.	Coupling Screw
øD	øD1	L	L1	PM			
22	12	81	47	55	HSK 63A 22 55	0.750	22-68
27	15	91	49	65	HSK 63A 27 65	0.800	27-610
32	20	101	56	75	HSK 63A 32 75	0.850	32-810
42	24	116	60	90	HSK 63A 42 90	0.950	42-1014
54	28	136	70	110	HSK 63A 54 110	1.300	54-1220
68	36	171	85	145	HSK 63A 68 145	1.850	68-1624

HSK 100

Dimension					Product Number	Kg.	Coupling Screw
øD	øD1	L	L1	PM			
22	12	89	55	55	HSK 100A 22 55	2.250	22-68
27	15	99	57	65	HSK 100A 27 65	3.350	27-610
32	20	104	59	75	HSK 100A 32 75	2.400	32-810
42	24	119	63	90	HSK 100A 42 90	2.500	42-1014
54	28	139	73	110	HSK 100A 54 110	2.850	54-1220
68	36	174	88	145	HSK 100A 68 145	3.450	68-1624
85	50	194	94	165	HSK 100A 85 65	4.100	85-1630
100	60	214	114	185	HSK 100A 100 185	5.500	100-2035

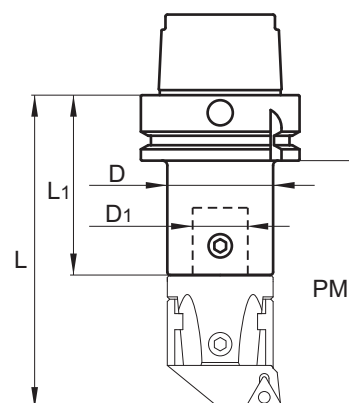

ARBORS FOR BORING HEADS

DIN 228

MORSE 2,3,4

MORSE 2

Dimension					Product Number	Kg.	Coupling Screw
øD	øD1	L	L1	PM			
22	12	105	71	80	302 22 80	0.450	22-68
27	15	73	31	55	302 27 55	0.250	27-610
27	15	128	83	100	302 27 100	0.550	27-610

MORSE 3

Dimension					Product Number	Kg.	Coupling Screw
øD	øD1	L	L1	PM			
22	12	110	76	100	303 22 80	0.600	22-68
27	15	78	36	55	303 27 55	0.500	27-610
27	15	130	88	100	303 27 100	0.800	27-610
32	20	84	39	60	303 32 60	0.500	32-810
32	20	160	115	130	303 32 130	0.880	32-810
42	24	114	58	90	303 42 90	0.750	42-1014
42	24	160	104	130	303 42 130	1.250	42-1014

MORSE 4

Dimension					Product Number	Kg.	Coupling Screw
øD	øD1	L	L1	PM			
22	12	136	102	100	304 22 100	1.100	22-68
22	12	166	132	130	304 22 130	1.200	22-68
27	15	82	40	55	304 27 55	0.850	27-610
27	15	137	95	100	304 27 100	1.200	27-610
27	15	167	125	130	304 27 130	1.300	27-610
32	20	88	43	60	304 32 60	0.850	32-810
32	20	166	121	130	304 32 130	1.350	32-810
32	20	196	151	160	304 32 160	1.600	32-810
42	24	104	48	75	304 42 75	1.000	42-1014
42	24	166	110	130	304 42 130	1.700	42-1014
42	24	196	140	160	304 42 160	2.000	42-1014
54	28	120	54	90	304 54 90	1.300	54-1220
54	28	196	130	160	304 54 160	2.900	54-1220
54	28	236	170	200	304 54 200	3.300	54-1220
68	36	235	149	200	304 68 200	4.150	68-1624
68	36	295	209	260	304 68 260	5.900	68-1624

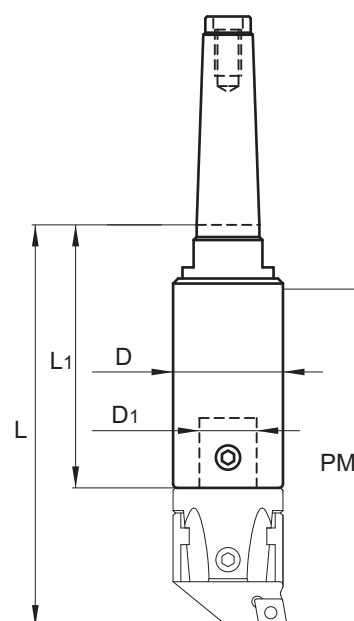

ARBORS FOR BORING HEADS

DIN 1806

MORSE 5

MORSE 5

Dimension					Product Number	Kg.	Coupling Screw
øD	øD1	L	L1	PM			
22	12	112	78	100	305 22 100	1.600	22-68
22	12	142	108	130	305 22 130	1.800	22-68
27	15	65	23	55	305 27 55	1.600	27-610
27	15	113	71	100	305 27 100	1.750	27-610
27	15	143	101	130	305 27 130	1.900	27-610
32	20	70	25	60	305 32 60	1.550	32-810
32	20	143	98	130	305 32 130	2.100	32-810
32	20	173	128	160	305 32 160	2.250	32-810
42	24	83	27	75	305 42 75	1.650	42-1014
42	24	188	86	130	305 42 130	2.250	42-1014
42	24	218	116	160	305 42 160	2.600	42-1014
54	28	172	106	160	305 54 160	3.200	54-1220
54	28	212	146	200	305 54 200	3.950	54-1220
68	36	146	60	140	305 68 140	2.750	68-1624
68	36	212	126	200	305 68 200	4.750	68-1624
68	36	272	186	260	305 68 260	6.400	68-1624
85	50	216	116	200	305 85 200	6.500	85-1630
85	50	276	176	260	305 85 260	8.500	85-1630
85	50	336	236	320	305 85 320	11.150	85-1630
*	100	276	176	260	305 100 260	10.000	100-2035
*	100	336	236	320	305 100 320	13.600	100-2035
*	100	146	56	140	505 160	4.400	M12X40

* ALSO FOR HEADS Ø200

* SEE PAGE 38: THE ASSEMBLY SYSTEM FOR LARGE BORING HEADS

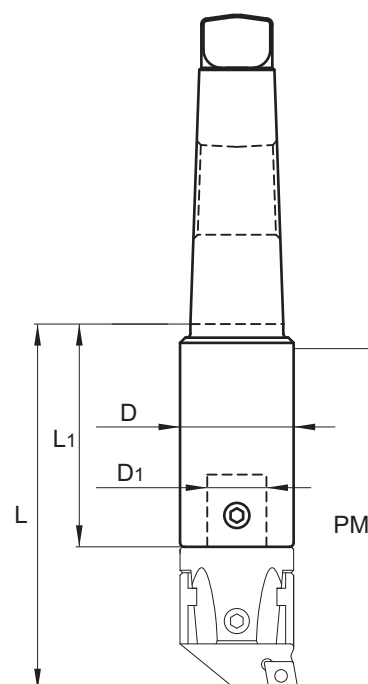

NOTE: MORSE 6 ARBORS CAN BE MANUFACTURED AS "SPECIAL" UPON REQUEST

ARBORS FOR BORING HEADS

DIN 1835

WELDON

WELDON Ø20, Ø25, Ø32, Ø40

Dimension					Product Number	Kg.	Coupling Screw
øD	øD1	øD2	L	PM			
20	22	12	16	50	B 20 22 50	0.150	22-68
20	22	12	70	100	B 20 22 100	0.300	22-68
25	27	15	14	55	B 25 27 55	0.250	27-610
25	27	15	58	95	B 25 27 100	0.450	27-610
32	32	20	18	60	B 32 32 60	0.450	32-810
32	32	20	58	100	B 32 32 100	0.700	32-810
32	32	20	118	160	B 32 32 160	1.050	32-810
32	32	24	40	90	B 32 42 90	0.750	42-1014
40	42	24	36	60	B 40 42 90	1.050	42-1014
40	42	24	106	160	B 40 42 160	1.925	42-1014

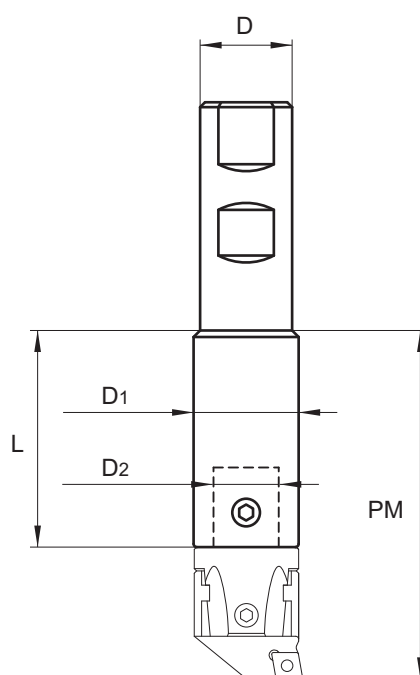

ARBORS FOR BORING HEADS

BRIDGEPORT HOLDERS

R8 HOLDERS

Dimension					Product Number	Kg.	Coupling Screw
ϕD	$\phi D1$	L	L1	PM			
22	12	54	20	50	R8 22 50	0.150	22-68
27	15	64	22	60	R8 27 60	0.250	27-610
32	20	79	34	75	R8 32 75	0.580	32-810
42	24	95	39	90	R8 42 90	0.750	42-1014
54	28	114	48	110	R8 54 110	1.040	54-1220

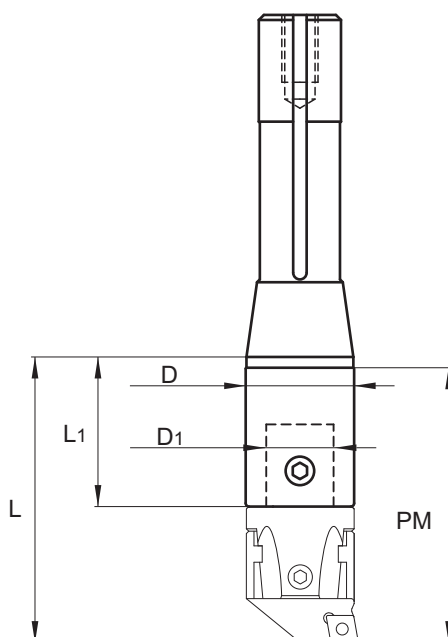

ACCESORIES

EXTENSION PIECES

Dimension				Product Number	Kg.	Coupling Screw
øD	øD1	øD2	L			
22	12	12	20	P 22 20	0.095	22-68
22	12	12	30	P 22 30	0.140	22-68
27	15	15	30	P 27 30	0.180	27-610
27	15	15	45	P 27 45	0.250	27-610
32	20	20	35	P 32 35	0.260	32-810
32	20	20	52	P 32 52	0.375	32-810
42	24	24	40	P 42 40	0.480	42-1014
42	24	24	60	P 42 60	0.700	42-1014
54	28	28	50	P 54 50	0.950	54-1220
54	28	28	75	P 54 75	1.400	54-1220
68	36	36	60	P 68 60	1.800	68-1624
68	36	36	90	P 68 90	2.600	68-1624
85	50	50	70	P 85 70	3.050	85-1630
85	50	50	105	P 85 105	4.450	85-1630
100	60	60	80	P 100 80	4.600	100-2035
100	60	60	120	P 100 120	7.100	100-2035

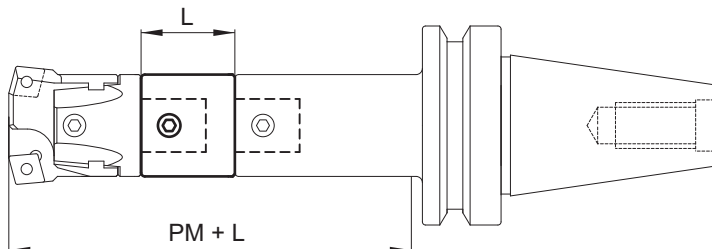
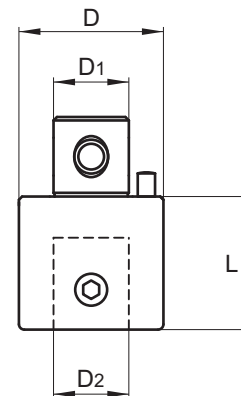

COOLANT-FEEDING EXTENSIONS (PROVIDES FLOOD COOLANT)

Dimension				Product Number	Kg.	Coupling Screw
øD	øD1	øD2	L			
22	12	12	30	P 22 30 R	0.140	22-68
27	15	15	30	P 27 30 R	0.180	27-610
32	20	20	35	P 32 35 R	0.260	32-810
42	24	24	40	P 42 40 R	0.480	42-1014
54	28	28	50	P 54 50 R	0.950	54-1220
68	36	36	60	P 68 60 R	1.800	68-1624
85	50	50	70	P 85 70 R	3.050	85-1630
100	60	60	80	P 100 80 R	4.600	100-2035

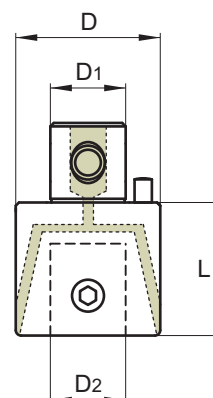

NOTE: Couplings to match with coolant-feeding extensions must be ordered by adding "R" at the end of the product number.

Example:
Standard Execution: BT 340 22 50
Coolant Execution: BT 340 22 50 R

ACCESORIES

REDUCERS

Dimension						Product Number	Kg.	Coupling Screw
øD	øD1	øD2	øD3	L	L1			
27	15	22	12	26	10	R 27 22 36	0.200	22-68
32	20	22	12	30	10	R 32 22 40	0.250	22-68
42	24	22	12	48	10	R 42 22 58	0.350	22-68
54	28	22	12	76	10	R 54 22 86	0.650	22-68
68	36	22	12	90	12	R 68 22 102	1.050	22-68
32	20	27	15	24	10	R 32 27 34	0.250	27-610
42	24	27	15	40	10	R 42 27 50	0.400	27-610
54	28	27	15	70	10	R 54 27 80	0.700	27-610
68	36	27	15	83	12	R 68 27 95	1.050	27-610
42	24	32	20	36	10	R 42 32 46	0.450	32-810
54	28	32	20	66	10	R 54 32 76	0.750	32-810
68	36	32	20	78	12	R 68 32 90	1.200	32-810
54	28	42	24	60	10	R 54 42 70	0.950	42-1014
68	36	42	24	70	12	R 68 42 82	1.400	42-1014
85	50	42	24	83	12	R 85 42 95	2.050	42-1014
68	36	54	28	60	12	R 68 54 72	1.650	54-1220
85	50	54	28	78	12	R 85 54 90	2.500	54-1220
85	50	68	36	88	12	R 85 68 100	3.350	68-1624
100	60	85	50	88	12	R 100 85 100	5.600	85-1630

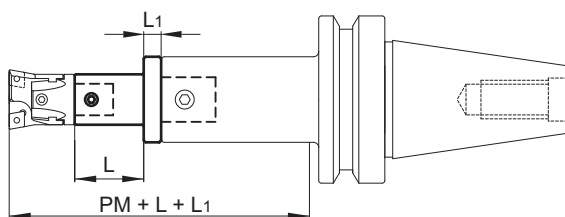
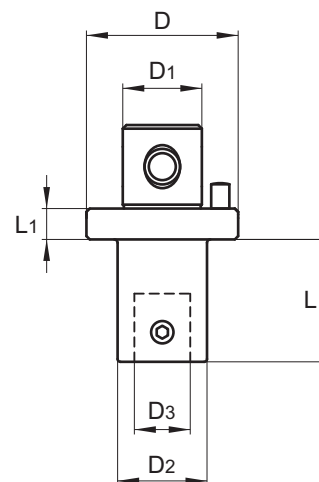

45° CHAMFERING HEADS

Dimension			Product Number	Insert	Clamp Screw	Kg.	Key	
øD	øD1	L					Clamp Key	Locking Key
22	43	24	CH 22	DCMT 11T3..	TT 409	0.100	T15	4
27	48	24	CH 27	DCMT 11T3..	TT 409	0.180	T15	4
32	62	30	CH 32	DCMT 11T3..	TT 409	0.260	T15	5
42	72	30	CH 42	DCMT 11T3..	TT 409	0.330	T15	5
54	94	40	CH 54	DCMT 1504..	TT 402	0.770	T20	6
68	110	40	CH 68	DCMT 1504..	TT 402	1.020	T20	8
85	145	55	CH 85	DCMT 1504..	TT 402	2.340	T20	10
100	170	60	CH 100	DCMT 1504..	TT 402	3.500	T20	14
100	200	60	CH 200	DCMT 1504..	TT 402	5.600	T20	14

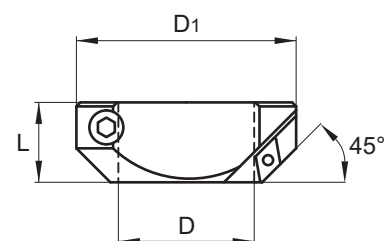

ACCESORIES

ADAPTORS

MILLING CUTTER HOLDER

Dimension				Product Number	Kg.
øD	øD1	øD2	L		
42	24	16	14	ADM 42-16	0.220
42	24	22	12	ADM 42-22	0.250
54	28	16	30	ADM 54-16	0.600
54	28	22	28	ADM 54-22	0.650
54	28	27	18	ADM 54-27	0.650
68	36	16	25	ADM 68-16	0.700
68	36	22	23	ADM 68-22	0.750
68	36	27	21	ADM 68-27	0.770
68	36	32	26	ADM 68-32	0.900
85	50	32	25	ADM 85-32	1.600
85	50	40	30	ADM 85-40	1.900

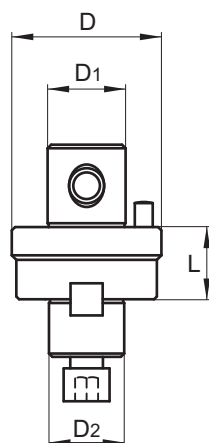

WELDON

Dimension				Product Number	Kg.
øD	øD1	øD2	L		
42	24	6	35	ADM 42 W6	0.500
42	24	8	35	ADM 42 W8	0.500
42	24	10	38	ADM 42 W10	0.550
42	24	12	55	ADM 42 W12	0.640
48	24	16	60	ADM 42 W16	0.640
52	24	20	65	ADM 42 W20	0.640
54	28	16	60	ADM 54 W16	1.150
54	28	20	65	ADM 54 W20	1.200
65	28	25	70	ADM 54 W25	1.250

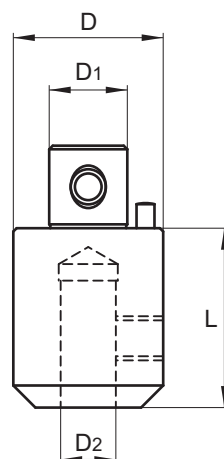

ACCESORIES

ADAPTORS

MORSE

Dimension					Product Number	Kg.
øD	øD1	øD2	øD3	L		
42	24	17.780	30	90	ADM 42 CM2	0.500
42	24	23.825	36	110	ADM 42 CM3	0.520
54	28	17.780	30	90	ADM 54 CM2	0.830
54	28	23.825	36	110	ADM 54 CM3	0.780

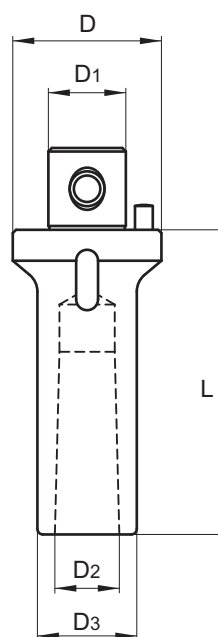

DIN 238 (FOR DRILL CHUCKS)

Dimension				Product Number	Kg.
øD	øD1	øD2	L		
42	24	12.065	8	ADM 42 B12	0.280
54	28	12.065	10	ADM 54 B12	0.330
54	28	15.733	10	ADM 54 B16	0.400
68	36	15.733	12	ADM 68 B16	0.650

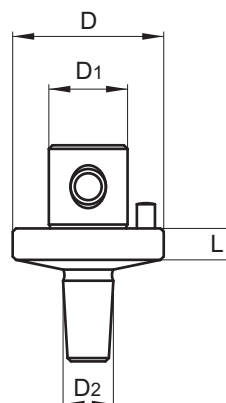

SPARE PARTS

FINISH BORING HEADS

INTEGRAL POCKET TYPE

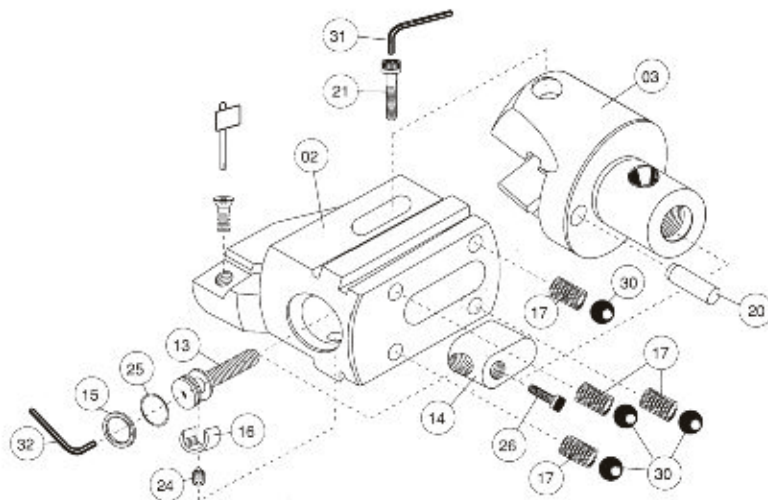

Ø	Boring Head	02	03	13	14	15	16	17	20	21	24	25	26	30	31	32
22	A 22 75 ...	A 2275 02 ...	A22 03	A22 13	A22 14	A22 15	A22 16	A22 17	D22 20	D22 21	D22 23	A22 25	A22 26	A22 30	HEX. 3	HEX. 2
	A 22 90 ...	A 2290 02 ...														
27	A 27 75 ...	A 2775 02 ...	A27 03	A27 13	A27 14	A27 15	A27 16	A27 17	D27 20	D27 21	D27 23	A27 25	A27 26	A27 30	HEX. 4	
	A 27 90 ...	A 2790 02 ...														
32	A 32 75 ...	A 3275 02 ...	A32 03	A32 13	A32 14	A32 15	A32 16	A32 17	D32 20	D32 21	D32 23	A32 25	A32 26	A32 30	HEX. 4	HEX. 2.5
	A 32 90 ...	A 3290 02 ...														
42	A 42 75 ...	A 4275 02 ...	A42 03	A42 13	A42 14	A42 15	A42 16	A42 17	D42 20	D42 21	D42 23	A42 25	A42 26	A42 30	HEX. 5	HEX. 3
	A 42 90 ...	A 4290 02 ...														
54	A 54 75 ...	A 5475 02 ...	A54 03	A54 13	A54 14	A54 15	A54 16	D42 09	D54 20	D54 21	A54 25	A54 26	A54 30	HEX. 6	HEX. 3	
	A 54 90 ...	A 5490 02 ...														

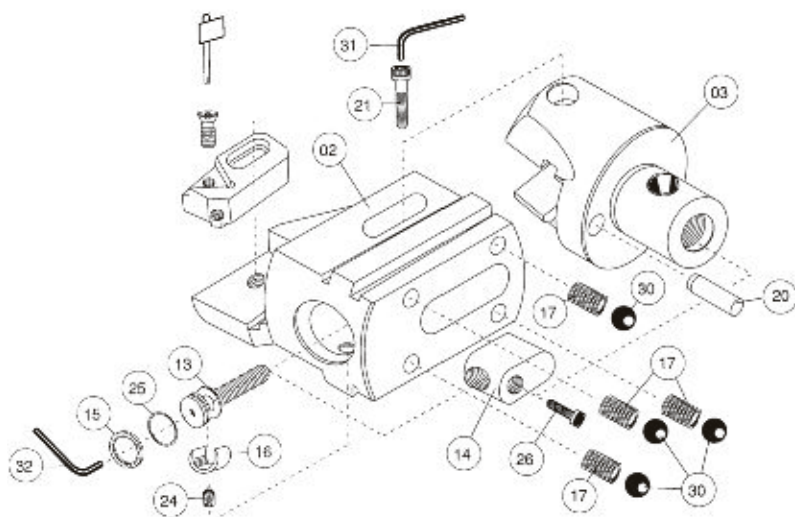

CARTRIDGE TYPE

Ø	Boring Head	02	03	13	14	15	16	17	20	21	24	25	26	30	31	32
68	A 68 ...	A 68..02 2CT	A68 03	A68 13	A68 14	A68 15	A68 16	A68 17	D68 20	D68 21	D68 23	A68 25	A68 26	A68 30	HEX. 8	HEX. 5
85	A 85 ...	A 85..02 3CT	A85 03	A85 13	A85 14	A85 15	A85 16	A85 17	D85 20	D85 21	D85 23	A85 25	A85 26	A85 30		HEX. 6
100	A 100 ...	A 100..02 3CT	A100 03													
200	A 200 ...	A 200..02 3CT	A200 03	A200 13												

SPARE PARTS

ROUGH BORING HEADS

INTEGRAL POCKET TYPE

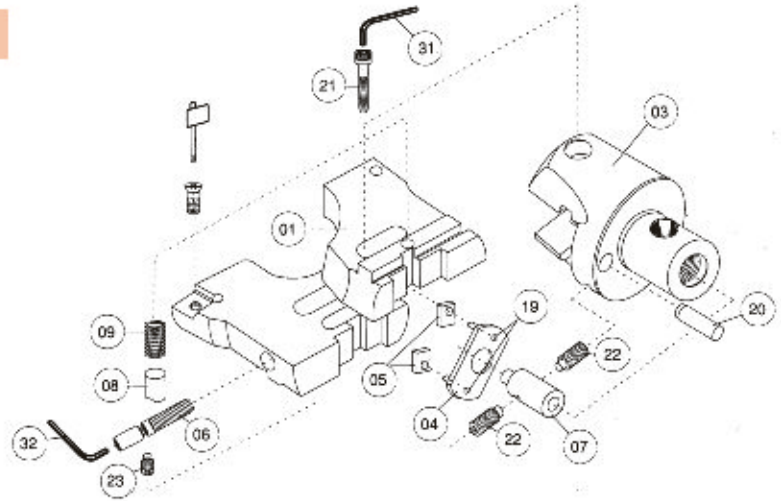

Ø	Boring Head	01	03	04	05	06	07	08	09	19	20	21	22	23	31	32
22	D 22 75 ...	D 2275 01 ...	D22 03	D22 04	-	D22 06			D22 09		D22 20	D22 21	D22 22	D22 23	HEX .3	HEX .2
	D 22 90 ...	D 2290 01 ...					D22 07	D22 08		D22 19						
27	D 27 75 ...	D 2775 01 ...	D27 03	D27 04	-	D27 06			D27 09		D27 20	D27 21	D27 22	D27 23	HEX .4	HEX .2
	D 27 90 ...	D 2790 01 ...														
32	D 32 75 ...	D 3275 01 ...	D32 03	D32 04	-	D32 06	D32 07	D32 08	D32 09	D32 19	D32 20	D32 21	D32 22	D32 23	HEX .4	HEX .2.5
	D 32 90 ...	D 3290 01 ...														
42	D 42 75 ...	D 4275 01 ...	D42 03	D42 04		D42 06	D42 07	D42 08			D42 20	D42 21	D42 22		HEX .5	HEX .3
	D 42 90 ...	D 4290 01 ...			D42 05				D42 09	D22 20				D42 23		
54	D 54 75 ...	D 5475 01 ...	D54 03	D54 04		D54 06	D54 07	D54 08			D54 20	D54 21	D54 22		HEX .6	HEX .3
	D 54 90 ...	D 5490 01 ...														

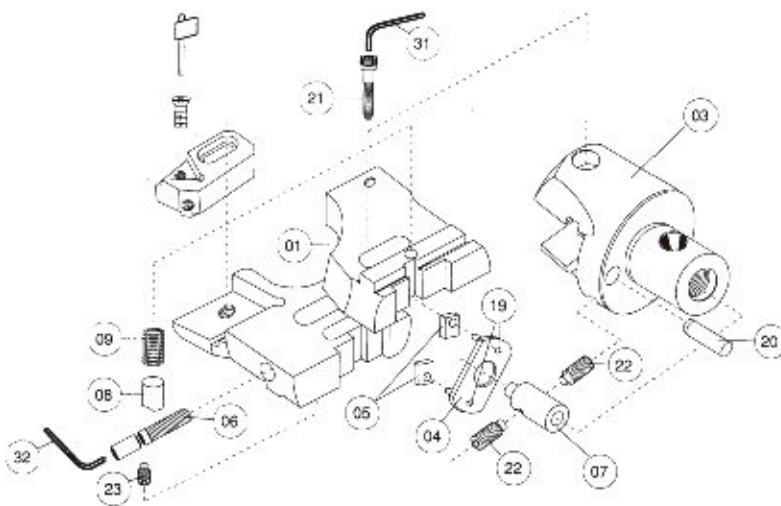

CARTRIDGE TYPE

Ø	Boring Head	01	03	04	05	06	07	08	09	19	20	21	22	23	31	32	
68	D 68 ...	D 68..01 2CT	D68 03	D68 04	D68 05	D68 06	D68 07	D68 08	D68 09	D68 19	D68 20	D68 21	D68 22	D68 23		HEX .5	
85	D 85 ...	D 85..01 3CT	D85 03	D85 04		D85 06	D85 07	D85 08			D85 20	D85 21			HEX .8	HEX .6	
100	D 100 ...	D 100..01 3CT	D100 03	D100 04	D85 05	D100 06	D100 07	D100 08	D85 09	D85 19	D100 20	D100 21	D85 22	D85 23			
200	D 200 ...	D 200..01 3CT	D200 03			D200 06											

SPARE PARTS

LARGE BORING HEADS

FINISHING

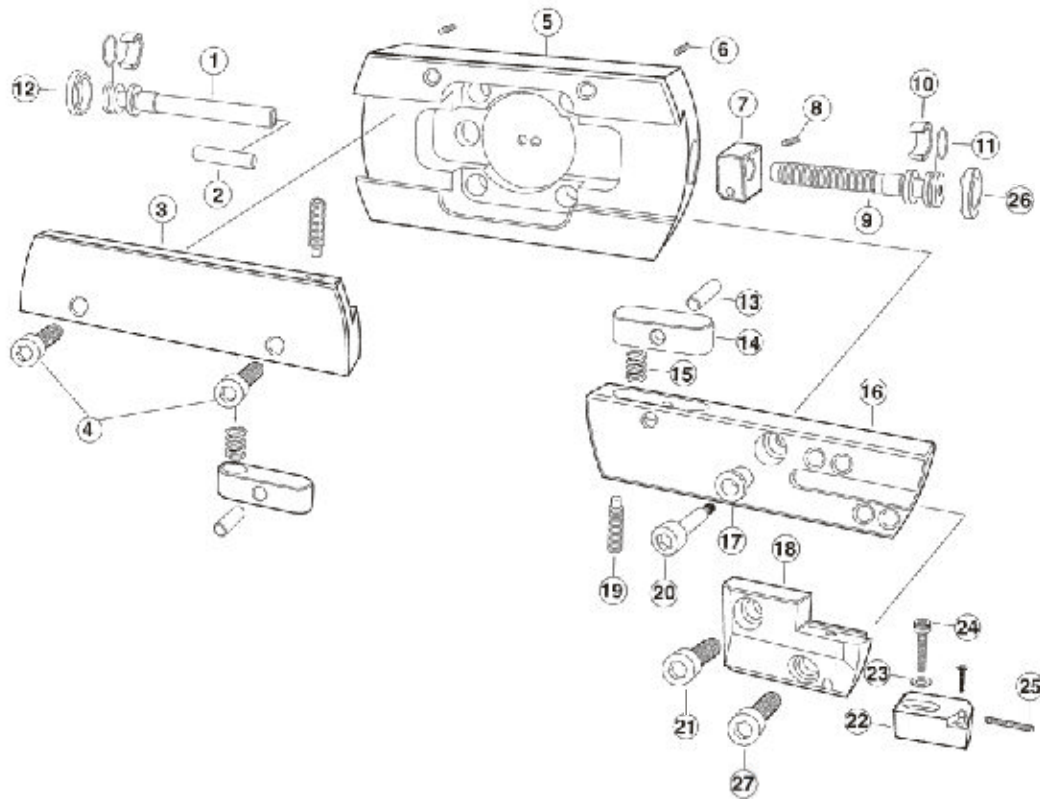

Boring Head	1	2	3	4	5	6	7	8	9	10	11	12	13	14	15	16	17	18	19	20	21	22	23	24	25	26	27
A 300	A300 52	D300 66	A300 02	A300 63	D300 03	D68 23	D300 54	D300 65	D300 50	A68 16	A68 25	A68 15	D300 60	D300 56	D300 59	D300 01	D300 62	D300 49	D300 58	D300 57	D300 61	3CT	D68 28	D85 27	D85 29	D300 15	D 300 61 2
A 400	A400 52	D300 66	A400 02	A300 63	D400 03	D68 23	D300 54	D300 65	D400 50	A68 16	A68 25	A68 15	D300 60	D300 56	D300 59	D400 01	D300 62	D300 49	D300 58	D300 57	D300 61	3CT	D68 28	D85 27	D85 29	D300 15	D 300 61 2
A 500	A500 52	D300 66	A500 02	A300 63	D500 03	D68 23	D300 54	D300 65	D500 50	A68 16	A68 25	A68 15	D300 60	D300 56	D300 59	D500 01	D300 62	D300 49	D300 58	D300 57	D300 61	3CT	D68 28	D85 27	D85 29	D300 15	D 300 61 2

SPARE PARTS

LARGE BORING HEADS

ROUGHING

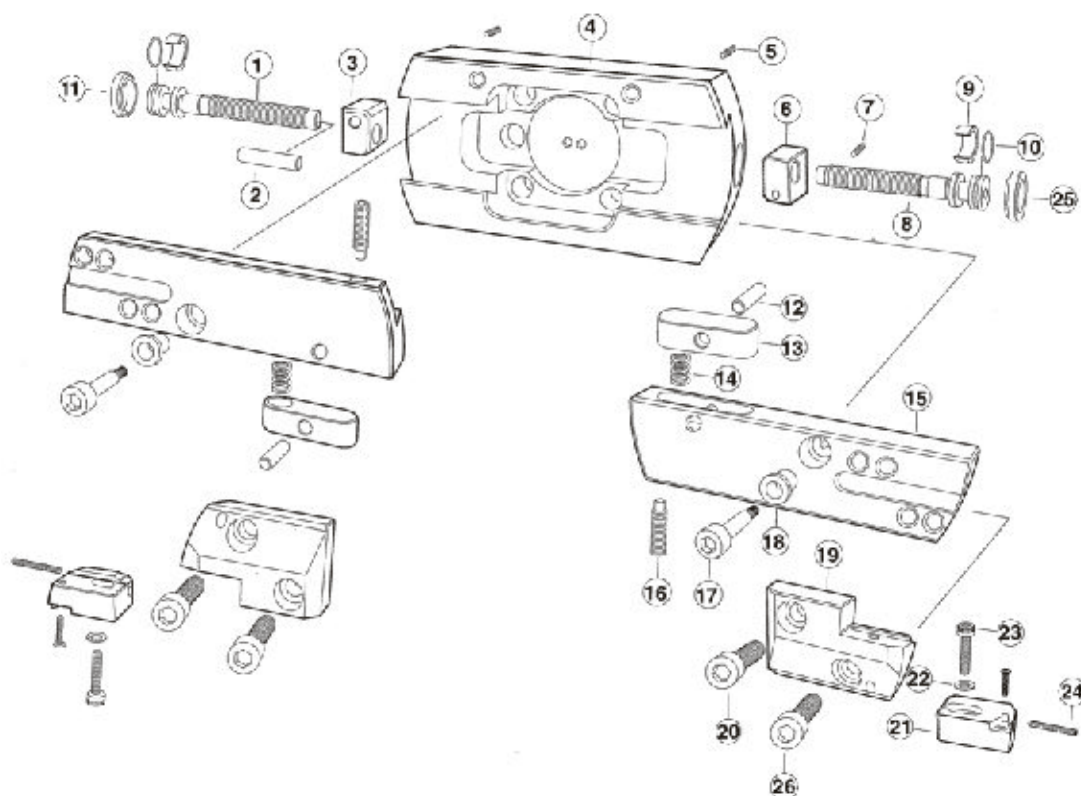

Boring Head	1	2	3	4	5	6	7	8	9	10	11	12	13	14	15	16	17	18	19	20	21	22	23	24	25	26
D 300	D300 51	D300 66	D300 55	D300 03	D68 23	D300 54	D300 65	D300 50	A68 16	A68 25	A68 15	D300 60	D300 56	D300 59	D300 01	D300 58	D300 57	D300 62	D300 49	D300 61	3CT	D68 28	D85 27	D85 29	D300 15	D 300 61 2
D 400	D400 51	D300 66	D300 55	D400 03	D68 23	D300 54	D300 65	D400 50	A68 16	A68 25	A68 15	D300 60	D300 56	D300 59	D400 01	D300 58	D300 57	D300 62	D300 49	D300 61	3CT	D68 28	D85 27	D85 29	D300 15	D 300 61 2
D 500	D500 51	D300 66	D300 55	D500 03	D68 23	D300 54	D300 65	D500 50	A68 16	A68 25	A68 15	D300 60	D300 56	D300 59	D500 01	D300 58	D300 57	D300 62	D300 49	D300 61	3CT	D68 28	D85 27	D85 29	D300 15	D 300 61 2

ASSEMBLY SYSTEM FOR LARGE BORING HEADS

ARBORS FOR LARGE BORING HEADS

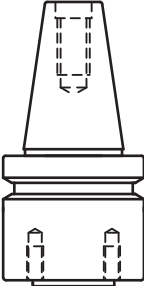
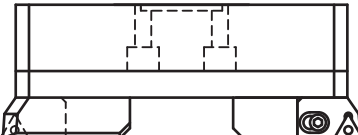
Ø		Product Number	Coupling Screw
		300 400 500	

DIRECT MOUNT

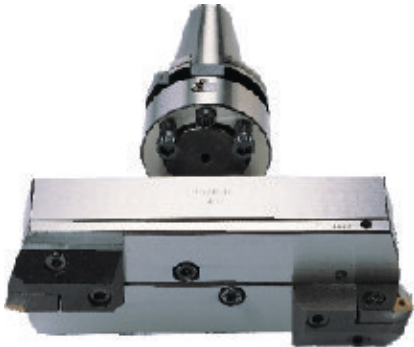

ADAPTOR FOR Ø100 STANDARD PINZBOHR ARBORS

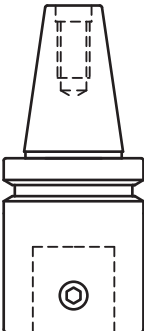
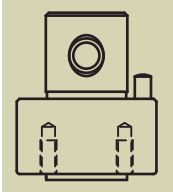
Ø		Dimension			Product Number	Kg.	Coupling Screw
		øD	øD1	L			
300 400 500		100	60	50	ADT 100-50	4.600	M12X40

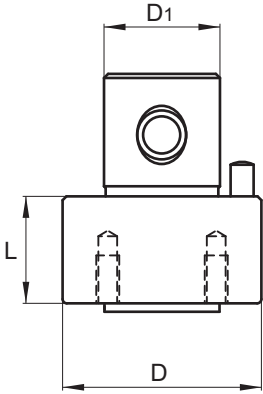







ADAPTOR MOUNT



INSERTS

INSERTS

Shape	Pinzbohr code	ISO code
	300 306 309	TCMT 16 T3.. TCMT 06 T1.. TCMT 09 02..
	400 401 402 409	CCMT 06 02.. CCMT 08 03.. CCMT 12 04.. CCMT 09 T3..
	404 405	EPGT 04 01..L EPMT 05 02..

Shape	Pinzbohr code	ISO code
	411 415	DCMT 11 T3.. DCMT 15 04..
	402N	CNMG 12 04..
	502 509	SCMT 12 04.. SCMT 09 T3..
	W 06 W 08	WCMT 06 T3.. WCMT 08 04..

